

Le partenaire professionnel de vos projets FM, TV, DAB+, DVBT, WEB

# M8

## COMPACT BROADCAST CONSOLE



## USER MANUAL

**B.BEAM SPRL**  
FM -TV-DAB-DVBT- Studio FM &TV  
Energie photovoltaïque sur réseau  
ou autonome

Zone Indust. Les Plénesses  
Rue du Progrès 8 B,  
4821 Andrimont,  
Belgique

Appel whatsapp gratuit 8-17h  
jours ouvrables : +32 475761453  
Tel.fixe bureau : +32 87228983

Heures d'ouvertures:

Du Lundi au jeudi : **de 8 à 12h & 13 à 17h**  
Vendredi : **de 8 à 12h & 13 à 15h**  
Week end : **fermé**

---

## **INDEX:**

Warning and Safety .....	pag. 4
Warranty Service.....	pag. 4
Technical Support.....	pag. 4
Box Content .....	pag. 4
First Aid Procedures .....	pag. 5-6
Declaration of Conformity .....	pag. 7
Description .....	pag. 8
Dimensions .....	pag. 9
MIC/LINE Input Module .....	pag. 10
MIC/LINE/USB Input Module .....	pag. 11
MIC/LINE/BLUETOOTH Input Module .....	pag. 12
TEL/LINE Input Module .....	pag. 13
MASTER Section .....	pag. 14
Connections - INPUTS.....	pag. 15
Connections - OUTPUTS .....	pag. 16
Example of Connection .....	pag. 17
Mixer Settings & Functions .....	pag. 18-20
Electrical Block Diagram .....	pag. 21-24
Technical Specifications .....	pag. 25
WEEE Directive.....	pag. 26
Company Profile.....	pag. 27

---

## WARNING and SAFETY

*Before attempting any operation, please follow the safety instructions contained in the following paragraph.*

The producer declines any liability for damage to people or things due to non-compliance, even if partial, of the following indications:

- Check the integrity of the product after removing the packaging.
- Ensure that the supply voltage corresponds to what is indicated on the apparatus.
- Ensure that the electrical system is equipped with a ground connection.
- Use only power sockets and cables with ground connection.
- Disconnect power before attempting any operation inside the device.
- The power cutting device is the power cord, so this should be easily accessible and the socket must be positioned close to the apparatus.
- Any operation involving the access to internal parts must be performed only by trained technician.
- Use only accessories suggested by the producer.
- Don't use this apparatus near water.
- Don't use objects that contains liquids near the mixer.



*This Symbol means that there is High Voltage inside the apparatus, so pay attention from electric shock.*



## WARRANTY

The equipment is warranted for a period of 2 years from the date of invoice. The warranty does not cover faults provoked by carelessness, natural causes and parts subject to wear.

The warranty will be voided if the equipment is mishandled. We suggest to contact the DM Technical Assistance first.

## TECHNICAL SUPPORT

Our Technical service answer 24 hours on 24 every day, so don't esitate to contact us for any question or problem.

Our contacts are:

**Phone:** +39 051 817657 - **mail:** [support@dmbroadcast.it](mailto:support@dmbroadcast.it)

## BOX CONTENT

- Mixer M8;
- M8 Rackmount Support;
- User Manual;
- Power Supply.

---

## FIRST AID PROCEDURES

All Personnel engaged in equipment installation, operation and maintenance must be familiar with First Aid Procedures and Routines.

### . Electric Shock Treatment

If the victim is UNCONSCIOUS:

- Lay the victim down on his/her back on a firm surface.
- Hold the neck and tilt the head backwards to free the airway system:

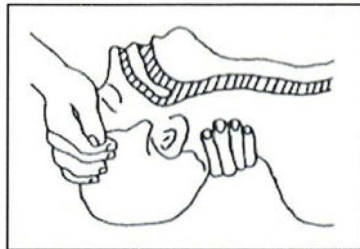

- If needed, open the victim's mouth and check for breathing.
- If there is no breathing, start artificial respiration without delay: tilt the head backwards, pinch the nostrils, seal your mouth around the victim's mouth and give 4 fast rescue breaths:

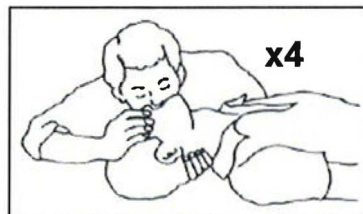

- Check for heartbeat; if there is no heartbeat, begin chest compressions immediately by placing your hands in the centre of the victim's chest:

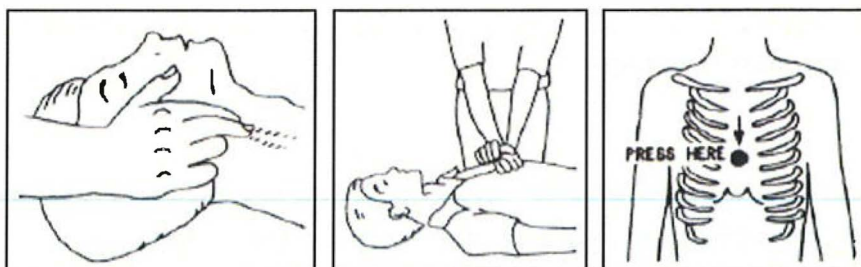

- 1 Rescuer: give 2 quick rescue breaths after each 15 compressions.
- 2 Rescues: one rescue breath after each 5 compressions.
- Do not stop chest compressions while giving artificial breathing.
- Call for medical help as soon as possible.

---

If the victim is CONSCIOUS:

- Cover the victim with a blanket.
- Try to reassure the victim.
- Loosen the victim's clothing and have him/her lie down.
- Call for medical help as soon as possible.

## **. Treatment of Electric Burns**

Large Burns and Broken Skin:

- Cover affected area with a clean cloth or linen.
- Do not break any blisters that have formed; remove any clothing or fabric that is stuck to the skin; apply adequate ointment.
- Administer adequate treatment for the type of accident.
- Get the victim to a Hospital as quickly as possible.
- Elevate arms and legs if injured.

If medical help is not available within an hour, the victim is conscious and is not retching, administer a solution of table salt and baking soda (one teaspoon of table salt to half teaspoon of baking soda every 250ml of water).

Have the victim slowly drink half a glass of solution for 4 times during a period of 15 minutes.

Stop at the first sign of retching.

Do not administer alcoholic beverages.

Minor Burns:

- Apply cold (not ice cold) strips of gauze or dress wound with clean cloth.
- Do not break any blisters that have formed; remove any clothing or fabric that is stuck to the skin; apply adequate ointment.
- If needed, have the victim change into clean, dry clothing.
- Administer adequate treatment for the type of accident.
- Get the victim to a Hospital as quickly as possible.
- Elevate arms and legs if injured.

---

## **DECLARATION OF CONFORMITY:**

Manufacturer Name: DM Broadcast s.r.l. Unipersonale

Manufacturer Address: Via Degli Orti, 1 - Funo di Argelato - Bologna, Italy

Product Description: *M8 - Compact Broadcast Audio Mixer*



Date: 16/09/2019

Authorized Company Representative:

**Marco Giovannini**  
CEO of DM Broadcast Engineering s.r.l.

Title of Signatory:

A handwritten signature in black ink, appearing to read "Marco Giovannini", written over a horizontal line.

---

## **DESCRIPTION**



**Front View**

The M8 is a Compact Broadcast Console designed by specialists in the Radio Broadcast field. This console includes the standard functions required from the radio stations like the TalkBack function to communicate with the guests during live transmissions, PFL to pre-listen the audio sources, the phantom power (+48V) required from the condenser microphones, relé for remote contacts. It also has new features for the Broadcast sector: USB line input (via USB audio codec), Bluetooth connection with portable devices. This console can be fixed on the rack or on a Flycase System thanks to his rackmountable supports (included in the box).



**Rear View**

This console is equipped with 6x MIC inputs, 2x L/R inputs, 1x USB input, 1x BLUETOOTH input connection, 2x TELEPHONE HYBRID lines, dedicated outputs for headphones, speakers, 1x L/R MAIN OUT, 1x auxiliary output (SUB).

## **DIMENSIONS:**

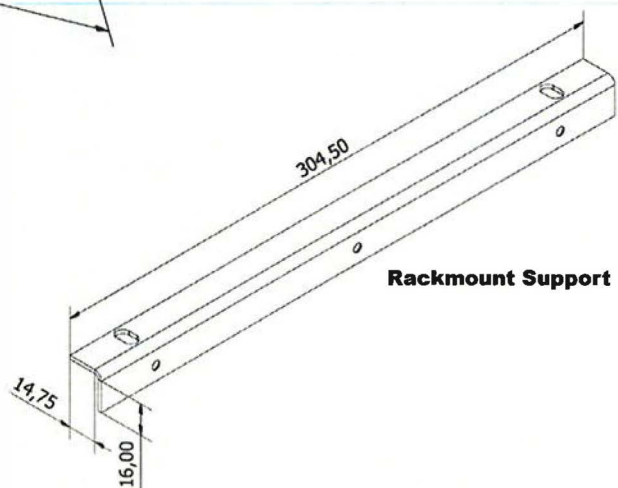
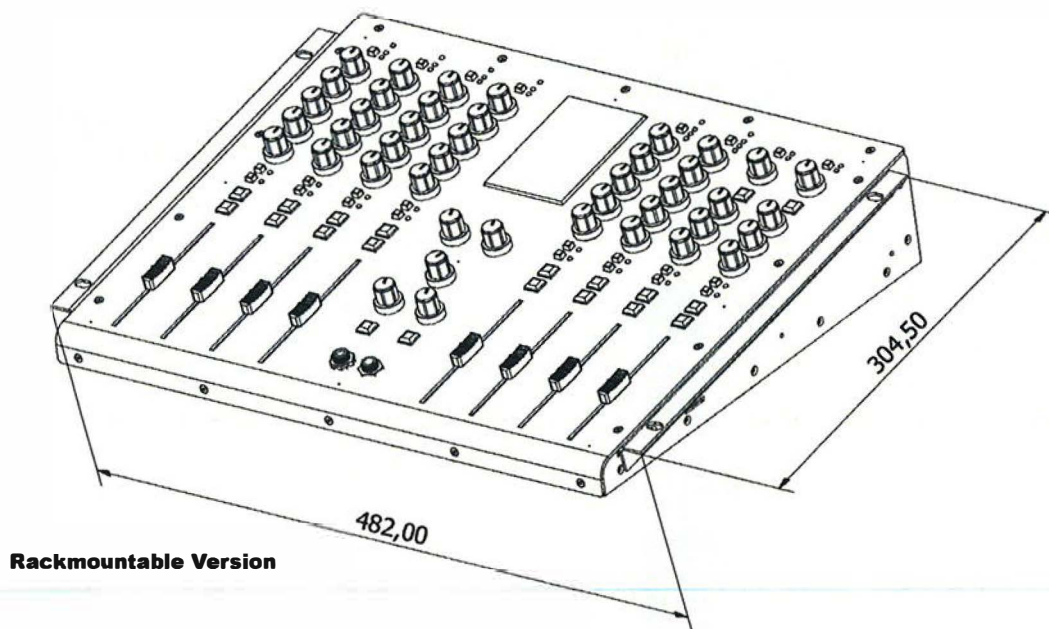
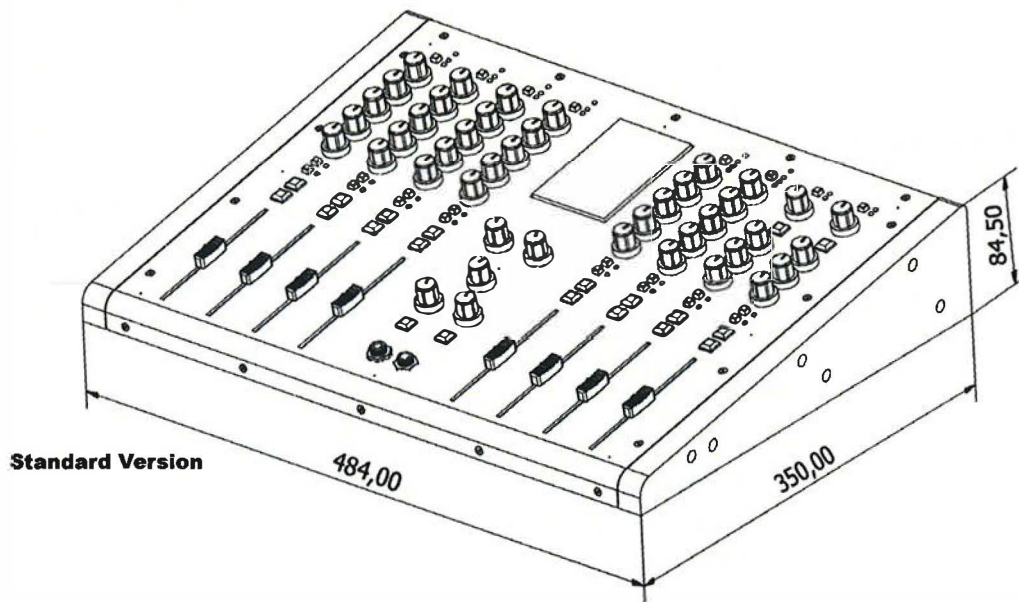



# MIC/LINE INPUT MODULE:

## INPUT SELECTOR

Switch to select the Line Input Source of the channel. (Hold for 1 second)

## GAIN

Adjust the Gain of the incoming signal level.

## MID

Adjust Medium Frequencies Band of the input signal.

## BAL

Adjust the level between the LEFT and the RIGHT channel of the input signal.

## PFL

Switch to activate the PFL on the input signal (Pre-Fader-Listen).

## FADER

Linear Fader controls the module overall level. It includes the r  le contact for external devices.

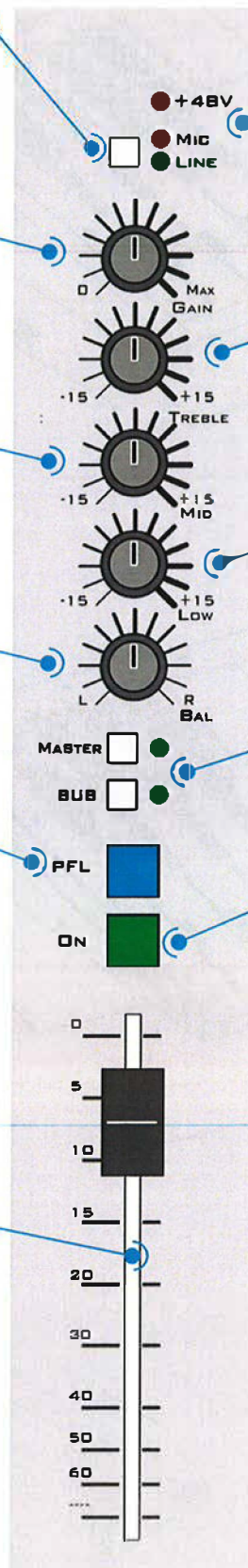

## LEDs

**48V:** Phantom Power Enabled/Disabled (ON/OFF) status of the Microphone Input.

**MIC/LINE:** Show the Line Input selected.

## TREBLE

Adjust High Frequencies Band of the input signal.

## LOW

Adjust Low Frequencies Band of the input signal.

## OUTPUT SELECTOR

Select the Output to enable between MASTER OUT and SUB OUT (or both). With LED status.

## ON

Channel ON/OFF Switch.

# MIC/LINE/USB INPUT MODULE:

## INPUT SELECTOR

Switch to select the Line Input Source of the channel.  
(Hold for 1 second)

## GAIN

Adjust the Gain of the incoming signal level.

## MID

Adjust Medium Frequencies Band of the input signal.

## BAL

Adjust the level between the LEFT and the RIGHT channel of the input signal.

## PFL

Switch to activate the PFL on the input signal (Pre-Fader-Listen).

## FADER

Linear Fader controls the module overall level. It includes the relet contact for external devices.

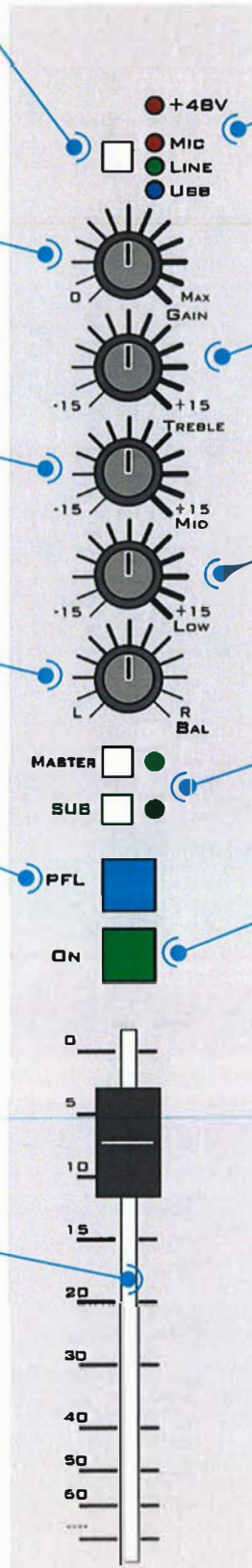

## LEDs

**48V:** Phantom Power Enabled/Disabled (ON/OFF) status of the Microphone Input.  
**MIC/LINE/USB:** Show the Line Input selected.

## TREBLE

Adjust High Frequencies Band of the input signal.

## LOW

Adjust Low Frequencies Band of the input signal.

## OUTPUT SELECTOR

Select the Output to enable between MASTER OUT and SUB OUT (or both).  
With LED status.

## ON

Channel ON/OFF Switch.

# MIC/LINE/BLUETOOTH INPUT MODULE:

## INPUT SELECTOR

Switch to select the Line Input Source of the channel. (Hold for 1 second)

## GAIN

Adjust the Gain of the incoming signal level.

## MID

Adjust Medium Frequencies Band of the input signal.

## BAL

Adjust the level between the LEFT and the RIGHT channel of the input signal.

## PFL

Switch to activate the PFL on the input signal (Pre-Fader-Listen).

## FADER

Linear Fader controls the module overall level. It includes the relet contact for external devices.

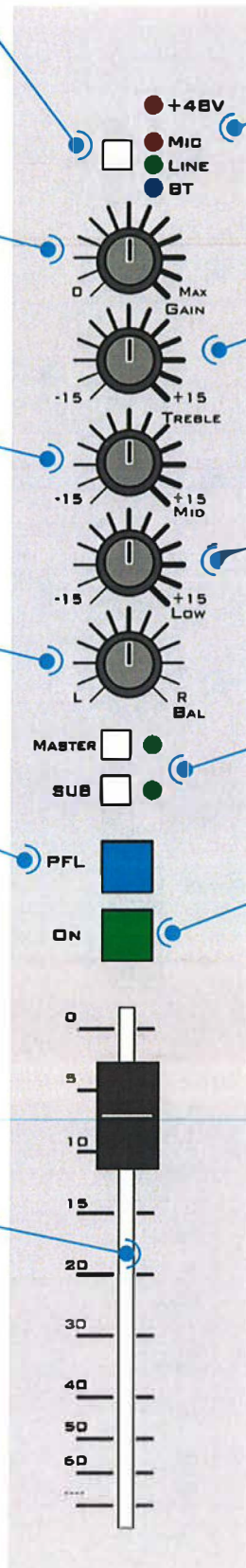

## LEDs

**48V:** Phantom Power Enabled/Disabled (ON/OFF) status of the Microphone Input.  
**MIC/LINE/BLUETOOTH:** Show the Line Input selected.

## TREBLE

Adjust High Frequencies Band of the input signal.

## LOW

Adjust Low Frequencies Band of the input signal.

## OUTPUT SELECTOR

Select the Output to enable between MASTER OUT and SUB OUT (or both). With LED status.

## ON

Channel ON/OFF Switch.

# TEL/LINE MODULE:

## INPUT SELECTOR

Switch to select the Line Input Source of the channel. (Hold for 1 second)

## GAIN

Adjust the Gain of the incoming signal level.

## SEND

Adjust the SEND signal level (signal sent to the caller).

## BAL

Adjust the level between the LEFT and the RIGHT channel of the input signal.

## PFL

Switch to activate the PFL on the input signal (Pre-Fader-Listen).

## FADER

Linear Fader controls the module overall level. It includes the rèle contact for external devices.

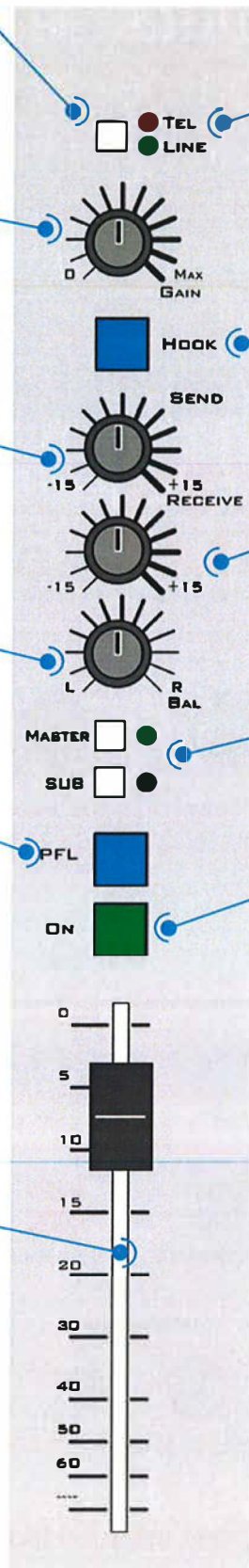

## LEDs

**48V:** Phantom Power Enabled/Disabled (ON/OFF) status of the Microphone Input.

**TEL/LINE:** Show the Line Input selected.

## HOOK

Switch to transfer the call on the internal telephone hybrid of the console.

## RECEIVE

Adjust the RECEIVE signal level (signal received from the caller).

## OUTPUT SELECTOR

Select the Output to enable between MASTER OUT and SUB OUT (or both). With LED status.

## ON

Channel ON/OFF Switch.

# MASTER SECTION:

## LCD DISPLAY

4" LCD Display to monitor the audio meters, the clock and the channel timer.



## STUDIO SPK.

Adjust the volume of the Studio Monitor Speaker Output (This output can be connected to the audio monitoring system of the Guest/Speaker Room).

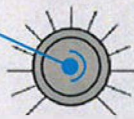

STUDIO

SPK.

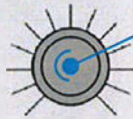

HDP.

## STUDIO HDP.

Adjust the volume of the Studio Headphone Output (This Output can be connected to the Headphone System of the Guest/Speaker Room).

## SUB OUT

Adjust the volume of the SUB Output (auxiliary out) of the console. (This output can be connected to an external audio recorder).

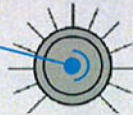

SUB

## C.ROOM SPK.

Adjust the volume of the Control Room Monitor Speaker Output (This output can be connected to the speaker system of the Control Room).

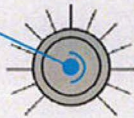

SPK.

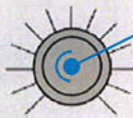

HDP.

## C.ROOM HDP.

Adjust the volume of the Control Room Headphone Output. This Knob control the volume of the Control Room Headphones located on the front panel of the console (Headphone Connector).

## C.ROOM SPK. MST/PFL

Switch to select the source to monitor on the control room (MASTER or PFL).



SPK. MST/PFL



TALK BACK

C.ROOM

## C.ROOM TALK BACK

Enable the Talk Back function to talk with the Guest/Speaker through the Guest/Speaker Room Headphone system.

HEADPHONE

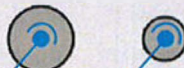

## C.ROOM HEADPHONE

Dedicated Connectors for the Control Room Headphones. (6.3mm and 3.5mm)

# CONNECTIONS - INPUT SECTION:

## USB INPUT

**USB B Type**  
USB line input for Laptop or Desktop Workstation.

## LINE INPUTS (L/R)

**PIN RCA**  
Unbalanced Stereo (L/R) Line Inputs.

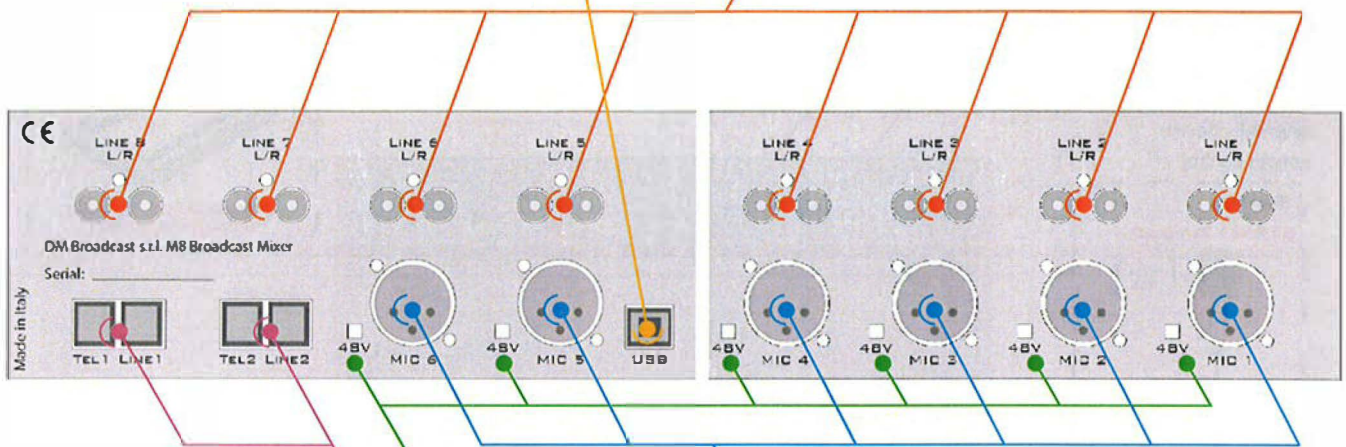

## 48V

Enable the Phantom Power required from the Condenser Microphones.

## MIC INPUTS (MONO)

**XLR Female**  
Balanced Microphone Inputs (Mono).

## TEL HYBRID INPUT

**RJ 11**  
Standard Telephone Connectors for Telephone Line & Hand-set Connection. Supported GSM and Standard Fixed Lines. N-1 Function included.

# CONNECTIONS - OUTPUT SECTION:

## SUB OUT

**PIN RCA**  
Auxiliary Output.

**EXAMPLE:**



**EXTERNAL RECORDER**  
(Available on Request)

## Rèlè

**EUROBLOCK**  
N.O. contact for external device remote control.

**EXAMPLE:**



**DM ONAIR LIGHT**  
(Available on Request)

## ST. HDP.

**PIN RCA**  
Dedicated Output for the Guest Headphone Distributor.

**EXAMPLE:**



**HEADPHONE DISTRIBUTOR**  
(Available on Request)

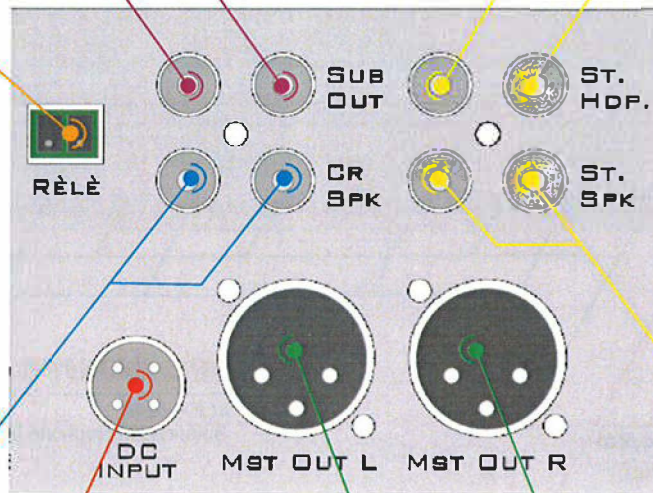

## ST. SPK.

**PIN RCA**  
Dedicated Output for the Guest Audio Monitor Speaker.

**EXAMPLE:**



**AUDIO MONITOR**  
(Available on Request)

## CR. SPK.

**PIN RCA**  
Dedicated Output for the Control Room Audio Monitor System.

**EXAMPLE:**



**AUDIO MONITOR**  
(Available on Request)

## DC INPUT

**POWER**  
DC Input: 24V - 3A.

## MST OUT L/R

**XLR M**  
MAIN OUTPUT of the console.

**EXAMPLE:**



**AUDIO PROCESSOR**  
(Available on Request)

# EXAMPLE OF CONNECTION

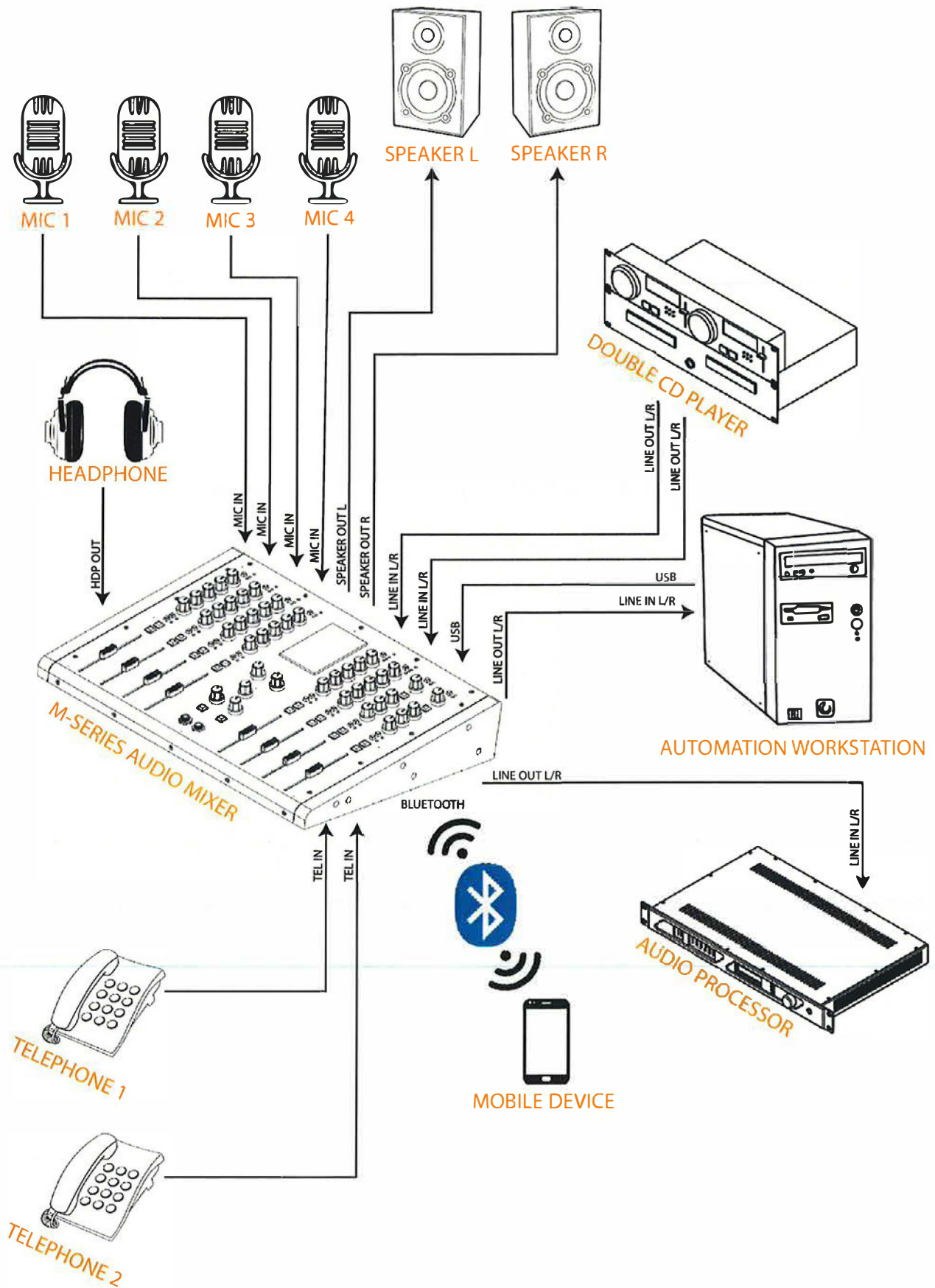



---

## **MIXER SETTINGS & FUNCTIONS**

### **BLUETOOTH PAIRING:**

1- Set the 6th Mixer Channel on Bluetooth Mode

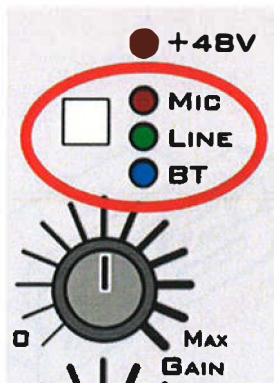

2- Press & Hold in the same time the buttons SPK. MST/PFL & TALK BACK (on the Master Section of the Mixer)

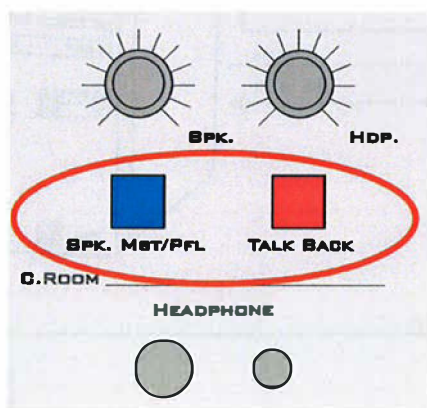

3- Activate the Bluetooth and Search for new device to pair on your Smartphone/Tablet/Laptop, the Bluetooth name of the console is "DM M8".

4- When you see the Bluetooth Console on your device, release your hand by holding the SPK. MST/PFL & TALK BACK buttons on the Master Section of the Mixer and pair the console with your device.

---

## SET TIME:

**\*ATTENTION\*** Before starting this configure procedure please check the Bluetooth mode on Channel 6 of the Mixer **MUST BE OFF**. After that you can proceed with the following steps.

1- Press & Hold in the same time the buttons SPK. MST/PFL & TALK BACK for 5 seconds (on the Master Section of the Mixer), after the Time on the Mixer Display start flashing.

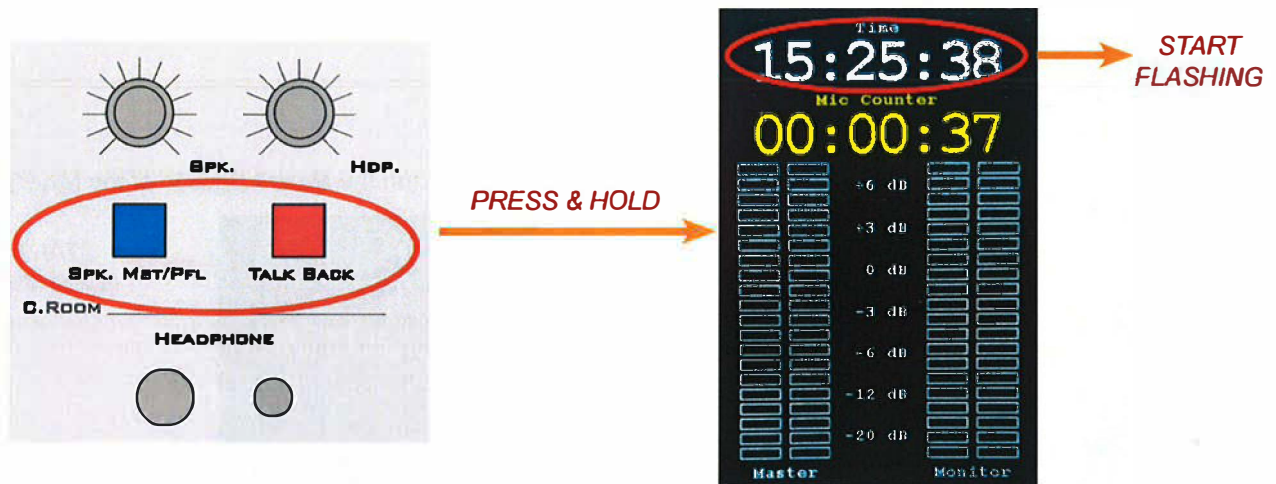

2- Press SPK. MST/PFL if you want to increase the value (by default you start to modify the hour value) and press TALK BACK to move from Hour to Minutes.

3- Once done press TALK BACK to move from minutes to exit the settings.

**MUTE FUNCTION CONFIG:** This configuration allow you to set which channel has to mute the Control Room or the Studio Speakers at channel activating from Channel 1 to Channel 6.

**\*ATTENTION\*** Before starting this configure procedure please check the Bluetooth mode on Channel 6 of the Mixer **MUST BE OFF**. After that you can proceed with the following steps.

1- Move the SEND KNOB of Channel 7 to the Middle Level Position.

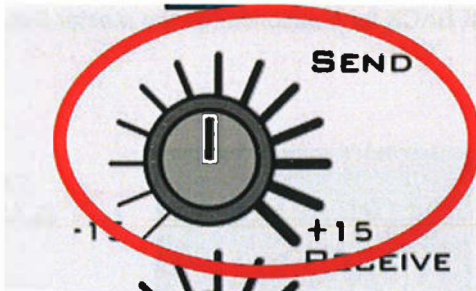

2- Press & Hold in the same time the buttons SPK. MST/PFL & TALK BACK (on the Master Section of the Mixer) until the Time on the Mixer Display start flashing.

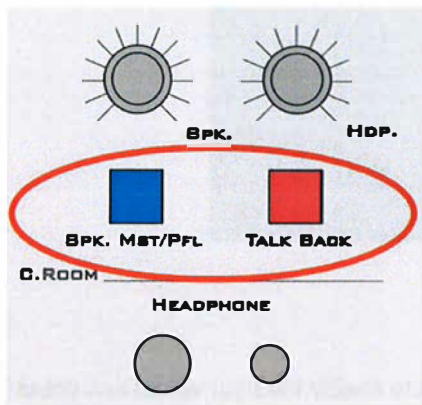

PRESS & HOLD



START FLASHING

3- Move the SEND KNOB of Channel 7 to the Minimum Level Position (to left).

4- Move the SEND KNOB of Channel 7 to the Maximum Level Position (to right).

5- Move the SEND KNOB of Channel 7 to the Middle Level Position, on the Mixer Display you have to see the following menu:

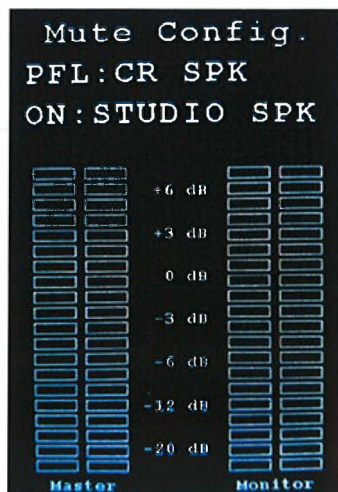

On each of the first 6 Channel press ON if you want to mute the STUDIO SPEAKER OUTPUT at channel open and press PFL if you wan to mute the CONTROL ROOM SPEAKER OUTPUT at channel open.

6- To exit from this configuration page Press & Hold the Buttons SPK. MST/PFL & TALK BACK (on the Master Section of the Mixer) until the Display comes back to the Time View page.

# ELECTRICAL BLOCK DIAGRAMS

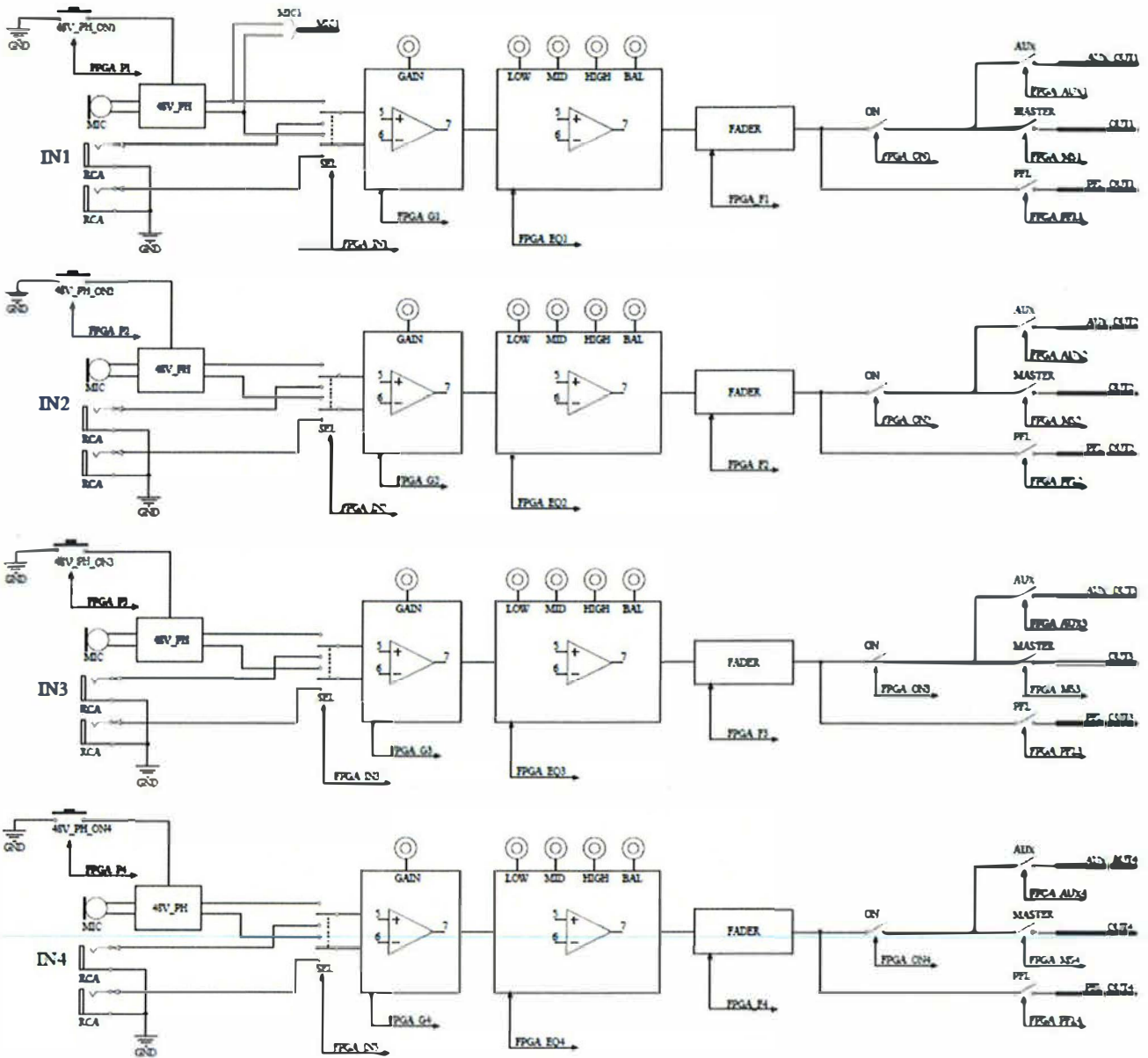

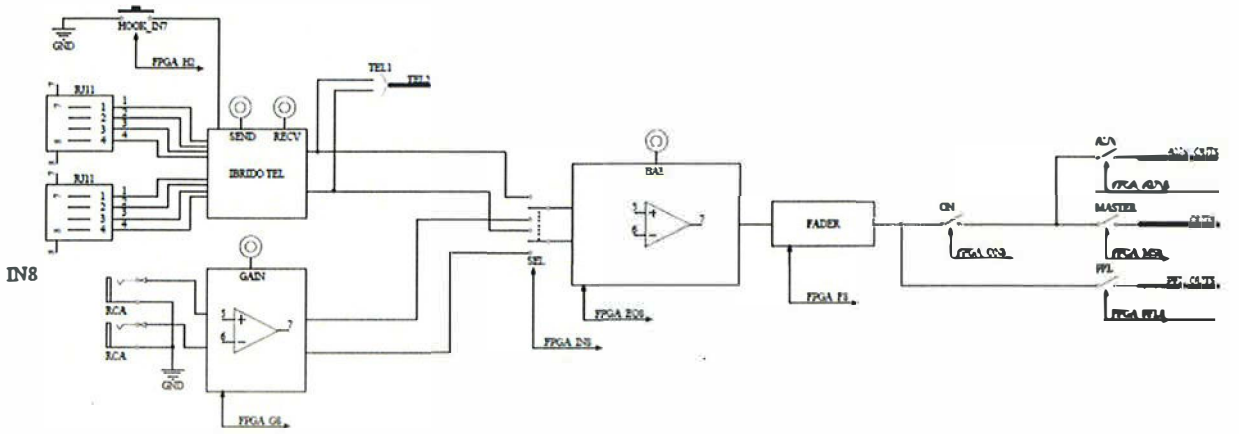
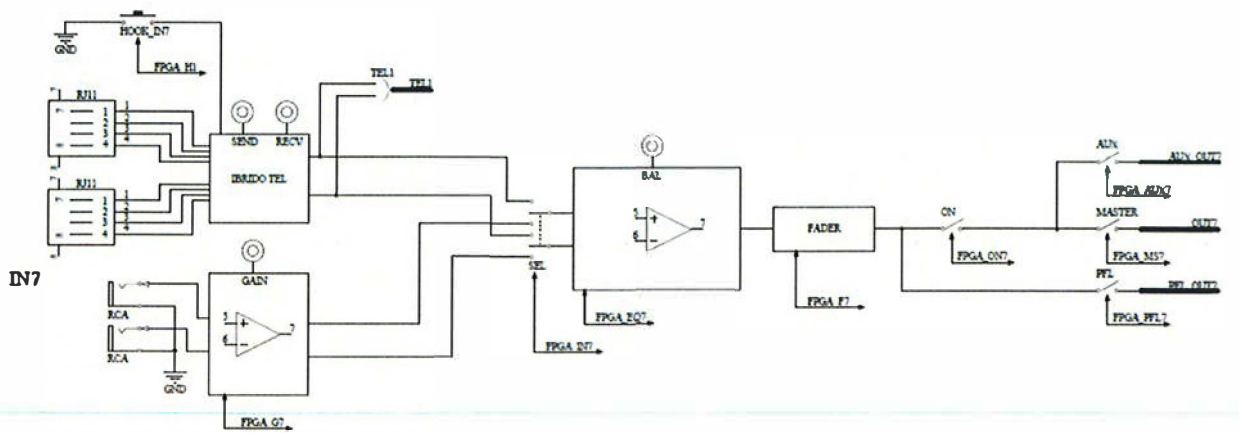
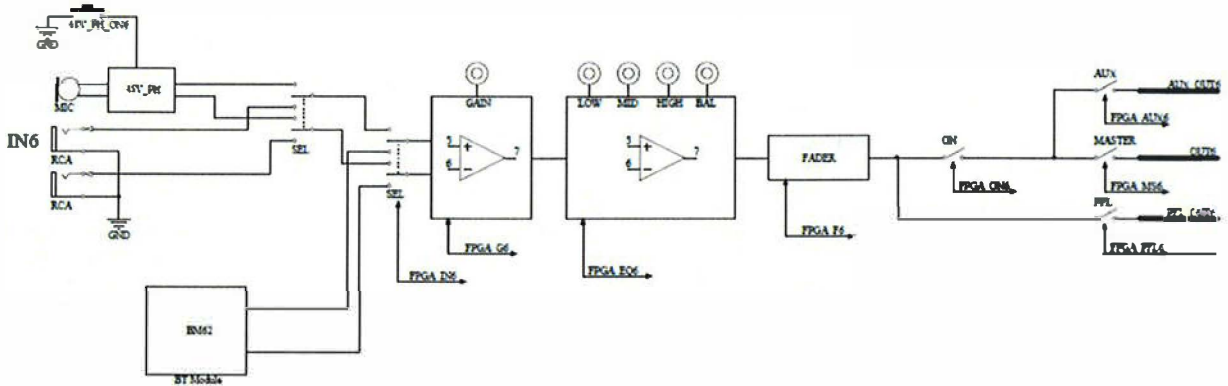
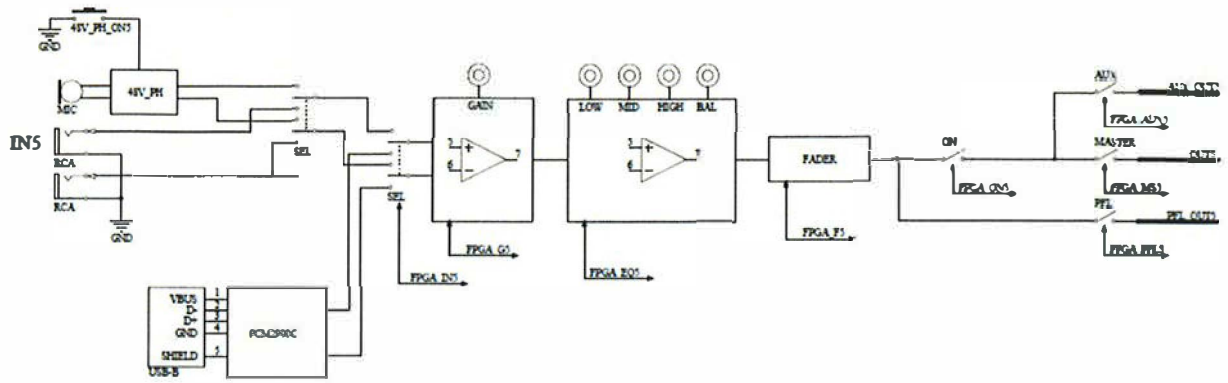

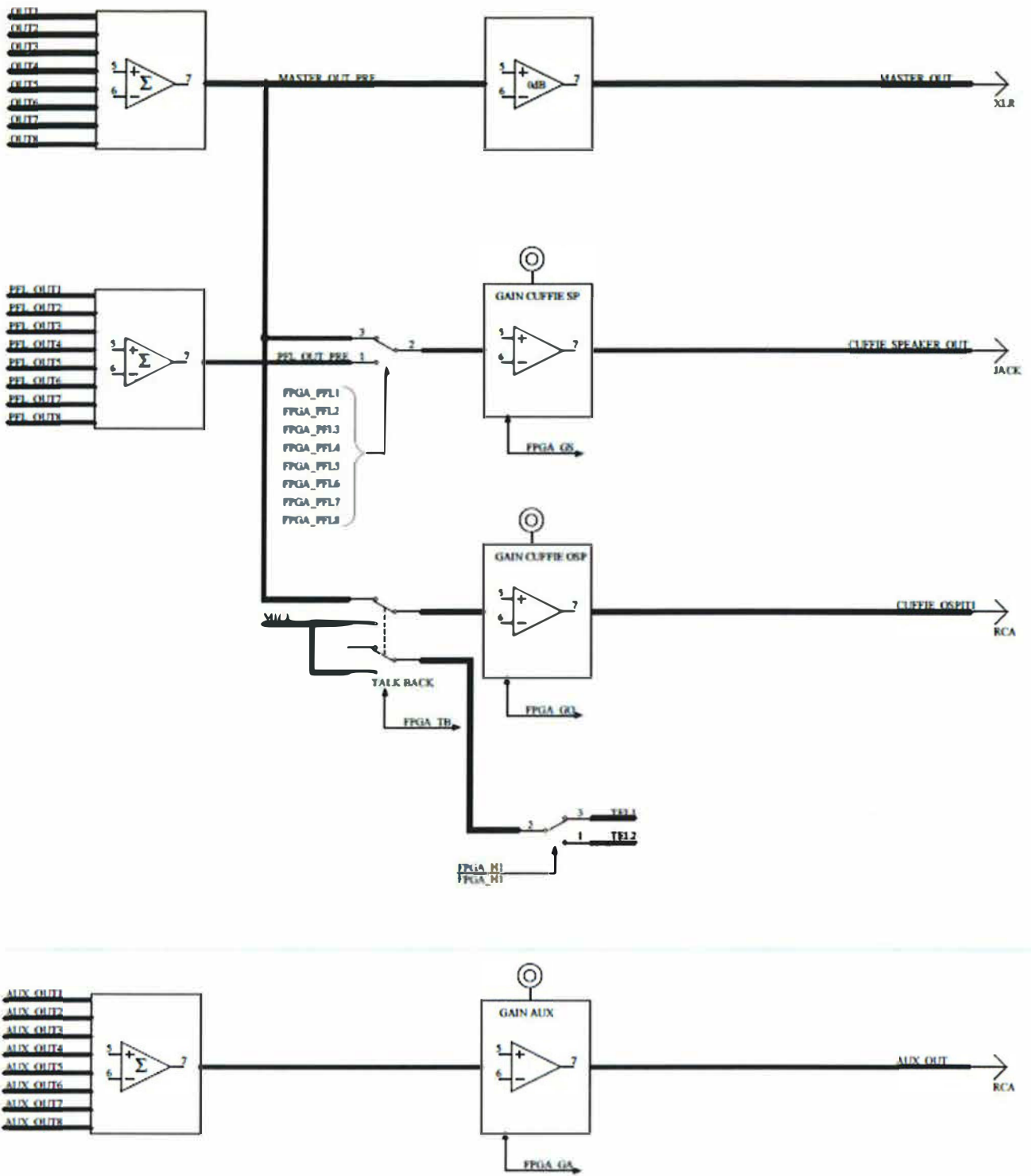

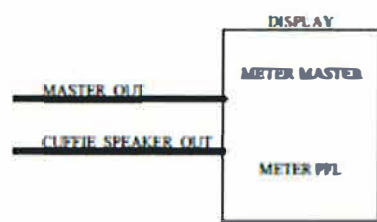
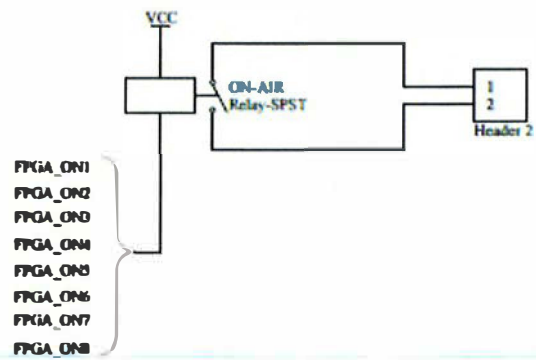
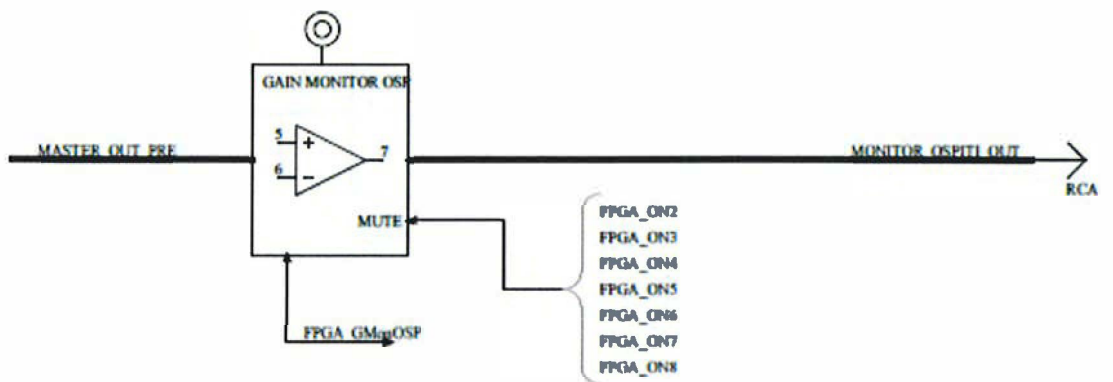
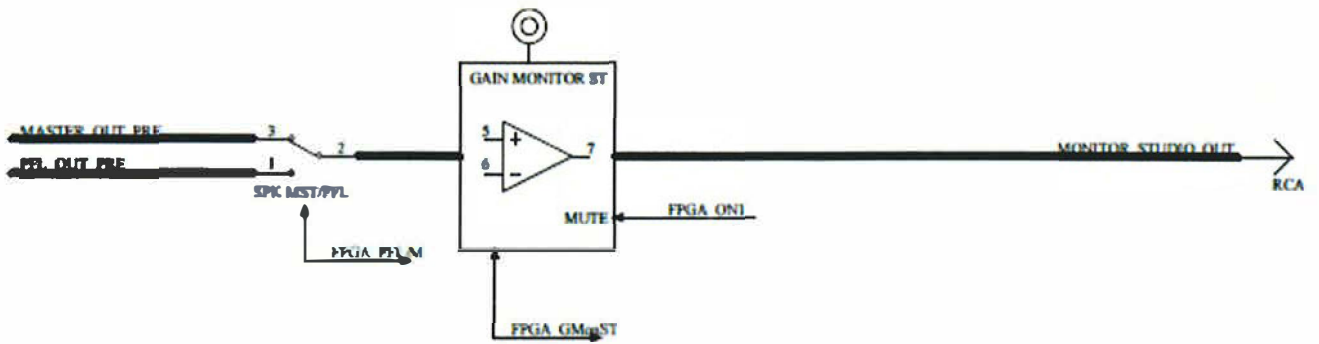

## TECHNICAL SPECIFICATIONS:

POWER SUPPLY	
Input	110-230 VAC @ 50/60 Hz
Output	24 VDC
Phantom power	48 VDC
MIC Input	
Connector	XLR Balanced - EMI Suppressed
Input impedance	> 1, 5Kohm
Input level	0dBu - OVL advise @ 3 dBu - Clipping @15dBu
Frequency response	15Hz - 30Khz @ 0dBu input
Noise	< -90 dB @ 1 Khz
Crosstalk L/R	< -65 dB @ 1 Khz
THD+N	< - 80 dB @1 Khz
Line Input	
Connector	RCA Unbalanced - EMI Suppressed
Input Impedance	10 Kohm
Input level	0dBu - OVL advise @ 3 dBu - Clipping @15dBu
Frequency response	15Hz - 30Khz @ 0dBu input
Noise	< -90 dB @ 1 Khz
Crosstalk L/R	< -6 5dB @ 1 Khz
THD+N	< - 80 dB @1 Khz
USB Input	
Connector	USB Type B - EMI Suppressed
Windows driver	not required
Mac OS driver	not required
Sample rate	48 Khz
Resolution	16 bit stereo
Channel	1 channel input
Bluetooth Input	
Pairing name	DM M8
Password	not required
N° device associable	5
Channel	1 channel input
Telephone Input	
Connector	RJ11
Frequency response	15Hz - 30Khz @ 0dBu input
Noise	< -90 dB @ 1 Khz
Crosstalk L/R	< -6 5dB @ 1 Khz
THD+N	< - 80 dB @1 Khz
Master Output	
Connector	2xXLR Balanced - EMI Suppressed
Output impedance	500 Ohm
Nominal Out level	0 dbu @ center gain
Max Out Gain	+ 12 dBu
Noise	< -90 dB @ 1 Khz
Crosstalk L/R	≤ -65 dB @ 1 Khz
THD+N	< - 80 dB @1 Khz
Aux, Monitor Output	
Connector	RCA Unbalanced - EMI Suppressed
Output impedance	500 Ohm
Nominal Out level	0 dbu @ center knob
Gain adjust	+/- 12 dBu
Noise	< -90 dB @ 1 Khz
Crosstalk L/R	< -65 dB @ 1 Khz
THD+N	< - 80 dB @1 Khz
System	
Display	4,0" TFT 480x320
Cpu	Cortex A9 - 667 Mhz - 1Gb Ram
Electronic technology	SMD + FPGA
Operative Temperature	0 °C - 60 °C
M8 Dimension	485x350x90 (WxDxH)
Weight	5,4 Kg



---

## WEEE Directive – Informativa RAEE



In line with EU Directive 2002/96/EC for waste electrical and electronic equipment (WEEE), this electrical product must not be disposed of as unsorted municipal waste. Please dispose of this product by returning it to the point of sale or to your local municipal collection point for recycling.

In Übereinstimmung mit der Richtlinie 2002/96/EG des Europäischen Parlaments und des Rates über Elektro- und Elektronik-Altgeräte (WEEE) darf dieses Elektrogerät nicht im normalen Hausmüll oder dem Gelben Sack entsorgt werden. Wenn Sie dieses Produkt entsorgen möchten, bringen Sie es bitte zur Verkaufsstelle zurück oder zum Recycling-Sammelpunkt Ihrer Gemeinde.

Conformément à la Directive 2002/96/EC sur les déchets d'équipements électriques et électroniques (DEEE), ce produit électrique ne doit en aucun cas être mis au rebut sous forme de déchet municipal non trié. Veuillez vous débarrasser de ce produit en le renvoyant à son point de vente ou au point de ramassage local dans votre municipalité, à des fins de recyclage.

In navolging van richtlijn 2002/96/EG van het Europees Parlement en de Raad betreffende afgedankte elektrische en elektronische apparatuur (AEEA) mag dit elektrische product niet als ongescheiden huisvuil worden weggedaan. Breng dit product terug naar de plaats van aankoop of naar het gemeentelijke afvalinzamelingspunt voor recycling.

In ottemperanza alla Direttiva UE 2002/96/EC sui rifiuti di apparecchiature elettriche ed elettroniche (RAEE), questo prodotto elettrico non deve essere smaltito come rifiuto municipale misto. Si prega di smaltire il prodotto riportandolo al punto vendita o al punto di raccolta municipale locale per un opportuno riciclaggio.

De conformidad con la Directiva 2002/96/CE de la UE sobre residuos de aparatos eléctricos y electrónicos (RAEE), este producto eléctrico no puede desecharse con el resto de residuos no clasificados. Deshágase de este producto devolviéndolo al punto de venta o a un punto de recogida municipal para su reciclaje.

I henhold til EU-direktiv 2002/96/EF om affald af elektrisk og elektronisk udstyr (WEEE) må dette udstyr ikke bortskaffes som usorteret husholdningsaffald. Bortskaf dette produkt ved at returnere det til salgsstedet eller til det lokale indsamlingssted, så det kan genbruges.

I linje med EU-direktiv 2002/96/EG om avfall som utgörs av eller innehåller elektriska eller elektroniska produkter (WEEE) får denna elektriska produkt inte bortskaffas som osorterat kommunalt avfall. Bortskaffa den i stället genom att lämna in den på försäljningsstället eller din lokala återvinningsstation.

EU:n sähkö- ja elektroniikkalaiteromudirektiivin (2002/96/EY) mukaisesti tätä elektroniikkalaitetta ei saa laittaa lajittelemattoman yhdyskuntajätteen sekaan. Hävitä laite palauttamalla se ostopaikkaan tai viemällä se elektroniikkaromun keräyspisteeseen.

De acordo com a Directiva Europeia 2002/96/EC sobre resíduos sólidos de equipamento eléctrico e electrónico (WEEE), este produto eléctrico não pode ser deixado fora juntamente com o lixo municipal indiferenciado. Por favor, no final da vida útil deste produto, devolva-o ao estabelecimento de aquisição, ou entregue no local de recolha apropriado para reciclagem designado pelo seu município.

V souladu se smrnici EU . 2002/96/ES o odpadních elektrických a elektronických zařizeniích (OEEZ) se tento elektrický výrobek nesmí likvidovat jako neřídny komunální odpad. PYi likvidaci tento výrobek vrat'te prodejci nebo ho odevzdejte k recyklaci do komunálního sborného zařizení.

Vastavalt EL direktiivile 2002/96/EÜ, mis käsitleb elektri- ja elektroonikaseadmete jäätmeid (WEEE), ei või antud toodet visata majapidamisjäätmete hulka. Palun tagastage antud toode taaskasutamise eesmärgil müügipunkti või kohaliku piirkonna jäätmekogumise punkti.

V súlade so smernicou 2002/96/ES o odpade z elektrických a elektronických zariadení (OEEZ) sa toto elektrické zariadenie nesmie odstranovať ako netriedený komunálny odpad. Výrobok odstráňte jeho vrátením v mieste nákupu alebo odovzdaním v miestnom zbernom zariadení na recyklovanie.