

SUMMARY

SAFETY WARNINGS/ISTRUZIONI PER LA SICUREZZA	5
PREFACE	5
SAFETY WARNINGS	6
CONSIGNES DE SÉCURITÉ IMPORTANTES	8
ISTRUZIONI IMPORTANTI PER LA SICUREZZA	10
WICHTIGE SICHERHEITSHINWEISE	13
INSTRUCCIONES IMPORTANTES DE SEGURIDAD	15
FIRST INSTALLATION RECOMMENDATIONS	18
POWER SUPPLY CABLE	18
PROTECTION AGAINST LIGHTNING	18
INSTALLATION NOTE AND FIRST STEP	19
BEST SETUP LOCATION	19
INTRODUCTION	20
1. GENERAL DESCRIPTION	21
1.1 MIXER DIMENSIONS	21
1.2 CUTTING TEMPLATE	22
1.3 TALKBOX DIMENSIONS	23
1.4 INPUT CONNECTIONS	24
1.5 OUTPUT CONNECTIONS	25
1.6 COMMUNICATION CONNECTORS	26
1.7 TALKBOX CONNECTIONS	27
2. SURFACE	28
2.1 INPUTS LED METER	29
2.2 OUTPUT LED METER	29
2.3 CONTROL INPUT CHANNEL	31
A. SET BUTTON	32
B. CHB BUTTON	32
C. GAIN	33
D. F1 BUTTON	33
E. EQ BUTTON	34
F. PGM/SUB/AUX-1/AUX-2 BUTTONS	35
G. FADER	36
H. FADER LED BAR	36
I. ON/START BUTTON	37
J. PFL BUTTON	38
2.4 SPECIAL FUNCTION BUTTONS	39
A. OUTPUT BUTTON	39
B. METER BUTTON	40
C. TELEPHONE	41
D. BLUETOOTH	41
2.5 MONITORS SECTION	42
A. CONTROL ROOM SPEAKERS (SPK-CRM)	42
B. CONTROL ROOM HEADPHONE (HDP-CRM)	45
C. STUDIO – SPEAKERS	46
D. STUDIO – HEADPHONES SOURCES & LEVEL	48
E. TALKBACK – FROM CONTROL ROOM TO THE STUDIO	49

2.6	SMART KEY / JINGLE BUTTONS*	49
2.7	DISPLAY 7" TFT AND CONTROL BUTTONS	50
	A. COLOR DISPLAY 7" - 800X480 RESOLUTION	50
	B. BUTTONS FOR THE MENU NAVIGATION	51
	C. ENCODER FOR THE MENU NAVIGATION	51
	D. MENU DISPLAY PARTS	52
3.	MENU	52
3.1	AUDIO/INPUTS	52
3.1.1	MIC (MIC-1 TO MIC-5)	53
3.1.1.1	NAME:	53
3.1.1.1	PREAMP:	54
3.1.1.2	GAIN:	54
3.1.1.3	EQ:	55
3.1.1.4	BAL/PAN:	58
3.1.1.5	PHASE:	58
3.1.1.6	PHANTOM 48V:	59
3.1.1.7	SPK-CUT:	59
3.1.2	MIC-5 INPUT / TELCO INPUT	64
3.1.3	MONO-1 TO MONO-6	66
	LINE-1, LINE-2, LINE-3	66
3.1.4	STEREO	67
3.1.5	AUX-IN	68
3.1.6	TEL/BT	69
	TELCO	69
	TELEPHONE HYBRID	70
	BLUETOOTH	71
3.1.7	DIGITAL	72
	AES/EBU	72
	USB-1, USB-2	72
3.2	AUDIO/OUTPUTS	74
	• 4 STEREO OUTPUT - XLR MALE - BALANCED AUDIO CONNECTION (47Ω)	74
	• 4 STEREO OUTPUT - PIN RCA - UNBALANCED AUDIO CONNECTIONS	74
	• 2 USB AUDIO CARD USB -TYPE B - PC CONNECTIONS	74
	• 2 STEREO OUTPUT - JACK 6.3MM - UNBALANCED AUDIO CONNECTION (NOMINAL 32Ω)	74
	• 6 RJ45 (SFTP CABLE) AUDIO AND GPIO CONNECTIONS	74
	• AES/EBU STEREO OUTPUT - XLR MALE - BALANCED DIGITAL CONNECTION (110Ω)	74
	• ANALOG TELEPHONE LINE - RJ11 - PSTN INTERFACE	74
	• BLUETOOTH STEREO/MONO OUTPUT - WIRELESS – SMARTPHONE	74
3.2.1	ANALOG & DIGITAL OUTPUTS	74
3.2.2	MONITORS	75
	SPK-CRM & SPK-STUDIO	75
	HDP (HEADPHONE) CRM, STUDIO & GUEST	78
3.2.3	TONE GEN. (TONE GENERATOR)	79
3.3	SETTINGS	80
	INPUT MODE	80
	EXT. INPUT	80
	PFL MODE	80
	SNAPSHOT	81
	AUDIO/SETTINGS/VJPRO	81
3.4	GENERAL SET.	82
	GPIO	82

COMMUNICATIONS	83
TCP-IP.....	83
TIME&DATE.....	83
TIME ZONE.....	84
ACCESS CODE	84
LIGHT & DISPLAY	85
SMART KEYS	86
ONAIR TRIGGERS.....	86
4. SERVICE	87
4.1 CONFIGURATION	87
4.2 SOFTWARE	88
A. UPGRADE	88
MIXER FIRMWARE UPGRADE.....	88
B. VERSION.....	89
4.3 LOGS	89
4.4 WEB LOGIN	89
TALKBOX CONNECTIONS AND FUNCTIONING	90
PINOUT OF CONNECTIONS	93
WEEE DIRECTIVE – INFORMATIVA RAEE	99
WARRANTY	100
DECLARATION OF CONFORMITY.....	101
DICHIARAZIONE DI CONFORMITA'	102

SAFETY WARNINGS/ISTRUZIONI PER LA SICUREZZA

SAFETY WARNINGS

CONSIGNES DE SÉCURITÉ IMPORTANTES

ISTRUZIONI IMPORTANTI PER LA SICUREZZA

WICHTIGE SICHERHEITSHINWEISE

INSTRUCCIONES IMPORTANTES DE SEGURIDAD

(Rel. 1.6)

PREFACE

For your safety and to prevent the warranty from being accidentally invalidated, please read carefully all the texts marked with the Warning Symbols



The information contained in this manual is subject to change without notice and does not constitute a commitment by the seller.

The manufacturer will not be liable for any loss or damage resulting from the use of information or any errors contained in this manual or resulting from any erroneous operation or hardware failure contained in the product.

It is recommended that any repair and maintenance of the product be carried out by the manufacturer or its authorized agents. The manufacturer assumes no responsibility for any loss or damage caused by service, maintenance, or repair by unauthorized personnel.

SAFETY WARNINGS

The installation and servicing instructions in this manual are for use by qualified personnel only.

Read All Instructions. All safety and operating instructions must be read before operating the product. They also must be retained for future reference, as it contains many useful hints for determining the best combination of equipment settings for Yr particular application.

Heed All Warnings. All warnings on the product and those listed in the operating instructions must be adhered to.

Heat. This product must be situated away from any heat sources such as radiators or other products (including power amplifiers or transmitters) that produce heat.

Power Sources. This product must be operated from the type of power source indicated on the marking label and in the installation instructions. If you are not sure of the type of power supplied to your facility, consult your local power company. Make sure the AC main voltage corresponds to that indicated in the technical specifications. If a different voltage (ex. 110/115 VAC) is available, open the equipment closure and set the voltage switch on the main supply circuit, located behind the AC socket.

Power Cord Protection. Power supply cords must be routed so that they are not likely to be walked on or pinched by items placed upon or against them. Pay particular attention to the cords at AC wall plugs and convenience receptacles, and at the point where the cord plugs into the product.

Use only with a cart, stand, tripod, bracket, or table specified by the manufacturer, or sold with the apparatus. When a cart is used, use caution when moving the cart/apparatus combination to avoid injury from tip-over.

Lightning. For added protection for this product during a lightning storm, or when it is left unattended and unused for long periods, unplug it from the AC wall outlet and the audio connections. This will prevent damage to the product due to lightning and power-line surges.

Installation. Configuration and installation should only be carried out by a competent installation engineer.

Cabling. Using high-quality wires, well-protected. Make sure the cable integrity.



This symbol alerts you to the presence of dangerous voltage inside the closure – voltage that may be sufficient to constitute a risk of shock. Do not perform any servicing other than that contained in the operating instructions. Refer all servicing to qualified personnel.



The exclamation point within an equilateral triangle is intended to alert the user to the presence of important operating and maintenance (servicing) instructions in the literature accompanying the appliance.



Do not change the voltage setting or replace the mains fuse without first turning the unit off and unplugging the mains cord.



Make sure the AC main voltage corresponds to that indicated in the technical specifications.

THIS APPARATUS MUST BE EARTHED!



To avoid the risk of fire, use the correct value fuse, as indicated on the label stuck on the right side of the unit.



This apparatus uses a single-pole main switch and does therefore not separate the unit completely from the mains power. To completely separate from mains power (f.i. in the event of danger) unplug the mains power cord. As the MAINS plug is the disconnect device, the disconnect device shall remain readily operable.

CONSIGNES DE SÉCURITÉ IMPORTANTES

Lire ces consignes.

Conserver ces consignes.

Observer tous les avertissements.

Suivre toutes les consignes.

Ne pas utiliser cet appareil à proximité de l'eau.

Ne pas obstruer les ouvertures de ventilation. Installer en respectant les consignes du fabricant.

Ne pas installer à proximité d'une source de chaleur telle qu'un radiateur, une bouche de chaleur, un poêle ou d'autres appareils (dont les amplificateurs) produisant de la chaleur.

Ne pas annuler la sécurité de la fiche de terre, la troisième branche est destinée à la sécurité. Si la fiche fournie ne s'adapte pas à la prise électrique, demander à un électricien de remplacer la prise hors normes.

Protéger le cordon d'alimentation afin que personne ne marche dessus et que rien ne le pince, en particulier aux fiches, aux prises de courant et au point de sortie de l'appareil.

Utiliser uniquement les accessoires spécifiés par le fabricant.

Utiliser uniquement avec un chariot, un support ou une table spécifié par le fabricant ou vendu avec l'appareil. Si un chariot est utilisé, déplacer l'ensemble chariot–appareil avec précaution afin de ne pas le renverser, ce qui pourrait entraîner des blessures.

Débrancher l'appareil pendant les orages ou quand il ne sera pas utilisé pendant longtemps.

Confier toute réparation à du personnel qualifié. Des réparations sont nécessaires si l'appareil est endommagé d'une façon quelconque, par exemple: cordon ou prise d'alimentation endommagé, liquide renversé ou objet tombé à l'intérieur de l'appareil, exposition de l'appareil à la pluie ou à l'humidité, appareil qui ne marche pas normalement ou que l'on a fait tomber.

NE PAS exposer cet appareil aux égouttures et aux éclaboussures. Ne pas poser des objets contenant de l'eau, comme des vases, sur l'appareil.



Ce symbole indique la présence d'une tension dangereuse dans l'appareil constituant un risque de choc électrique.



Ce symbole indique que la documentation fournie avec l'appareil contient des instructions d'utilisation et d'entretien importantes.



Avant de modifier le commutateur de changement de tension ou replacer le fusible il faut débrancher l'appareil de la prise électrique. Pendant son usage, l'appareil doit être branché à la prise de terre.



Utiliser le fusible principal AC avec la valeur qui est indiquée sur l'étiquette collée sur le coffret.



Assurez-vous que la tension principale AC correspond à celle indiquée dans les spécifications techniques.



L'interrupteur d'alimentation interrompt un pôle du réseau d'alimentation excepté le conducteur de terre de protection. En cas de danger, débrancher le cordon d'alimentation. Parce que la prise du réseau de alimentation est utilisée comme dispositif de déconnexion, ce dispositif doit demeurer aisément accessible.

ISTRUZIONI IMPORTANTI PER LA SICUREZZA

Leggere le presenti istruzioni.

Conservare queste istruzioni.

Osservare tutte le avvertenze.

Seguire scrupolosamente tutte le istruzioni.

Non usare questo apparecchio in prossimità di acqua.

Non ostruire alcuna apertura per il raffreddamento. Installare l'apparecchio seguendo le istruzioni.

Non installare l'apparecchio accanto a fonti di calore quali radiatori, aperture per l'afflusso di aria calda, forni o altri apparecchi (amplificatori inclusi) che generino calore.

Non rimuovere il terminale di connessione a terra sul cordone di alimentazione: esso ha lo scopo di tutelare l'incolumità dell'utilizzatore. Se la spina in dotazione non si adatta alla presa di corrente, rivolgersi ad un elettricista per far eseguire le modifiche necessarie.

Evitare di calpestare il cavo di alimentazione o di comprimerlo, specialmente in corrispondenza della spina e del punto di inserzione sull'apparato.

Utilizzare solo dispositivi di collegamento e gli accessori specificati dal produttore.

Utilizzare l'apparecchio solo con un carrello, un sostegno, una staffa o un tavolo di tipo specificato dal produttore o venduto insieme all'apparecchio. Se si utilizza un carrello, fare attenzione negli spostamenti per evitare infortuni causati da ribaltamenti del carrello stesso.

Scollegare l'apparecchio dalla presa di corrente durante i temporali o quando inutilizzato a lungo.

Per qualsiasi intervento, rivolgersi a personale di assistenza qualificato. È necessario intervenire sull'apparecchio ogniqualvolta si verificano danneggiamenti di qualsiasi natura. Ad esempio, la spina o il cavo di alimentazione sono danneggiati, è entrato liquido nell'apparecchio o sono caduti oggetti su di esso, l'apparecchio è stato esposto alla pioggia o all'umidità, non funziona normalmente o è caduto.

Non esporre a sgocciolamenti o spruzzi. Non appoggiare sull'apparecchio oggetti pieni di liquidi, ad esempio vasi da fiori.

Il prodotto deve essere connesso ad impianti costruiti secondo la regola dell'arte e muniti di protezione differenziale del circuito con valore non superiore agli 0,03A.

Tenere il prodotto lontano da liquidi.

Il prodotto deve essere utilizzato solo se integro e non danneggiato. Se il prodotto è stato sottoposto a forti urti o fosse venuto a contatto con liquidi è necessario contattare l'assistenza prima di accenderelo.

Il prodotto non va aperto per nessun motivo, non va modificato o manomesso. E' vietato tentare qualsiasi tipo di riparazione.

E' obbligatorio leggere il manuale utente prima di utilizzare il prodotto.

Il prodotto deve essere utilizzato da persone adulte. Tenere il prodotto fuori dalla portata dei bambini

Il prodotto va collegato ad impianti costruiti secondo la regola dell'arte e muniti di protezioni magnetotermiche del circuito.

E' proibito sovraccaricare le prese di corrente. E' obbligatorio spegnere il prodotto se non utilizzato.

E' proibito ostruire le aperture di raffreddamento e aerazione.

E' obbligatorio tenere materiali infiammabili/combustibili lontani dal prodotto.

E' vietato utilizzare il prodotto in presenza di sostanze che possano creare atmosfera esplosiva.

Il prodotto va utilizzato posizionato e utilizzato in maniera stabile.



Questo simbolo indica la presenza di alta tensione all'interno dell'apparecchio, che comporta rischi di scossa elettrica.



Questo simbolo indica la presenza di istruzioni importanti per l'uso e la manutenzione nella documentazione in dotazione all'apparecchio.



Non sostituire il fusibile o cambiare la tensione di alimentazione senza aver prima scollegato il cordone di alimentazione. **L'APPARATO DEVE ESSERE CONNESSO A TERRA.**



Sostituire il fusibile generale con uno di identico valore, come indicato sulla etichetta applicata sul mobile dell'apparato



Assicurarsi che la tensione di rete corrisponda a quella per la quale è configurato l'apparecchio.



Questo apparato utilizza un interruttore di alimentazione di tipo unipolare e l'isolamento dalla rete elettrica non è pertanto completo. Per ottenere un isolamento totale (ad esempio in caso di pericolo), scollegare il cordone di alimentazione. Inoltre, poichè la spina di alimentazione è utilizzata come dispositivo di sezionamento, essa deve restare facilmente raggiungibile.

WICHTIGE SICHERHEITSHINWEISE

Diese Hinweise LESEN.

Diese Hinweise AUFHEBEN.

Alle Warnhinweise BEACHTEN.

Alle Anweisungen BEFOLGEN.

Dieses Gerät NICHT in der Nähe von Wasser verwenden.

KEINE Lüftungsöffnungen verdecken. Gemäß den Anweisungen des Herstellers einbauen.

Nicht in der Nähe von Wärmequellen, wie Heizkörpern, Raumheizungen, Herden oder anderen Geräten (einschließlich Verstärkern) installieren, die Wärme erzeugen.

Die Schutzfunktion des Schukosteckers NICHT umgehen. Bei Steckern für die USA gibt es polarisierte Stecker, bei denen ein Leiter breiter als der andere ist; US-Stecker mit Erdung verfügen über einen dritten Schutzleiter. Bei diesen Steckerausführungen dient der breitere Leiter bzw. der Schutzleiter Ihrer Sicherheit. Wenn der mitgelieferte Stecker nicht in die Steckdose passt, einen Elektriker mit dem Austauschen der veralteten Steckdose beauftragen.

VERHINDERN, dass das Netzkabel gequetscht oder darauf getreten wird, insbesondere im Bereich der Stecker, Netzsteckdosen und an der Austrittsstelle vom Gerät.

NUR das vom Hersteller angegebene Zubehör und entsprechende Zusatzgeräte verwenden.

NUR in Verbindung mit einem vom Hersteller angegebenen oder mit dem Gerät verkauften Transportwagen, Stand, Stativ, Träger oder Tisch verwenden. Wenn ein Transportwagen verwendet wird, beim Verschieben der Transportwagen-Geräte-Einheit vorsichtig vorgehen, um Verletzungen durch Umkippen.

Das Netzkabel dieses Geräts während Gewittern oder bei längeren Stillstandszeiten aus der Steckdose ABZIEHEN.

Alle Reparatur- und Wartungsarbeiten von qualifiziertem Kundendienstpersonal DURCHFÜHREN LASSEN. Kundendienst ist erforderlich, wenn das Gerät auf irgendeine Weise beschädigt wurde, z.B. wenn das Netzkabel oder der Netzstecker beschädigt wurden, wenn Flüssigkeiten in das Gerät verschüttet wurden oder Fremdkörper hineinfließen, wenn das Gerät Regen oder Feuchtigkeit ausgesetzt war, nicht normal funktioniert oder fallen gelassen wurde.

Dieses Gerät vor Tropf- und Spritzwasser SCHÜTZEN. KEINE mit Wasser gefüllten Gegenstände wie zum Beispiel Vasen auf das Gerät STELLEN.



Dieses Symbol zeigt an, dass gefährliche Spannungswerte, die ein Stromschlagrisiko darstellen, innerhalb dieses Geräts auftreten.



Dieses Symbol zeigt an, dass das diesem Gerät beiliegende Handbuch wichtige Betriebs- und Wartungsanweisungen enthält.



Vor Änderung der Netzspannung oder Sicherungswechsel Netzkabel trennen.
Das Gerät muss für den Betrieb geerdet werden.



Vor Änderung der Netzspannung oder Sicherungswechsel Netzkabel trennen.
Das Gerät muss für den Betrieb geerdet werden.



Hauptsicherung nur mit einer gleichwertigen austauschen
(s. entsprechende Etikette).



Vor Einschalten Netzspannungseinstellung am Gerät überprüfen bzw. anpassen.



Inpoliger Netzschalter. In Notfälle oder für Wartungsarbeiten Netzkabel trennen. Der Netzstecker fungiert auch als Trennelement muss deshalb zugänglich bleiben.

INSTRUCCIONES IMPORTANTES DE SEGURIDAD

LEA estas instrucciones.

CONSERVE estas instrucciones.

PRESTE ATENCION a todas las advertencias.

SIGA todas las instrucciones.

NO utilice este aparato cerca del agua.

NO obstruya ninguna de las aberturas de ventilación. Instálese según lo indicado en las instrucciones del fabricante.

No instale el aparato cerca de fuentes de calor tales como radiadores, registros de calefacción, estufas u otros aparatos (incluyendo amplificadores) que produzcan calor.

NO anule la función de seguridad del enchufe polarizado o con clavija de puesta a tierra. Un enchufe polarizado tiene dos patas, una más ancha que la otra. Un enchufe con puesta a tierra tiene dos patas y una tercera clavija con puesta a tierra. La pata más ancha o la tercera clavija se proporciona para su seguridad. Si el toma corriente no es del tipo apropiado para el enchufe, consulte a un electricista para que sustituya el toma corriente de estilo anticuado.

PROTEJA el cable eléctrico para evitar que personas lo pisen o estrujen, particularmente en sus enchufes, en los toma corrientes y en el punto en el cual sale del aparato.

UTILICE únicamente los accesorios especificados por el fabricante.

UTILICESE únicamente con un carro, pedestal, escuadra o mesa del tipo especificado por el fabricante o vendido con el aparato. Si se usa un carro, el mismo debe moverse con sumo cuidado para evitar que se vuelque con el aparato.

DESENCHUFE el aparato durante las tormentas eléctricas, o si no va a ser utilizado por un lapso prolongado.

TODA reparación debe ser llevada a cabo por técnicos calificados. El aparato requiere reparación si ha sufrido cualquier tipo de daño, incluyendo los daños al cordón o enchufe eléctrico, si se derrama líquido sobre el aparato o si caen objetos en su interior, si ha sido expuesto a la lluvia o la humedad, si no funciona de modo normal, o si se ha caído.

NO exponga este aparato a chorros o salpicaduras de líquidos. **NO** coloque objetos llenos con líquido, tales como floreros, sobre el aparato .



Este símbolo indica que la unidad contiene niveles de voltaje peligrosos que representan un riesgo de choques eléctricos.



Este símbolo indica que la literatura que acompaña a esta unidad contiene instrucciones importantes de funcionamiento y mantenimiento.



Antes de cambiar la alimentación de voltaje o de cambiar el fusible, desconecte el cable de alimentación. Para reducir el riesgo de descargas eléctricas, esta unidad debe ser conectada a tierra.



Replazze el fusible con lo mismo, que corresponde a lo indicado en el panel del equipo.



Antes de encender, controlar que la línea de alimentación de voltaje corresponda a la indicada.



El interruptor de alimentación es unipolar. En el caso de peligro, desconecte el cable de alimentación. Porque la clavija de conexión a red sirve por la desconexión de la unidad, la clavija debe ser ubicada en proximidad de la unidad.

UNPACKING AND INSPECTION

Your equipment was packed carefully at the factory in a container designed to protect the unit during shipment. Nevertheless, we recommend making a careful inspection of the shipping carton and the contents for any signs of physical damage.

Damage & Claims

If the damage is evident, do not discard the container or packing material. Contact your carrier immediately to file a claim for damages. Customarily, the carrier requires you, the consignee, to make all damage claims. It will be helpful to retain the shipping documents and the waybill number.

Save all packing materials! If You should ever have to ship the unit (e.g. for servicing), it is best to ship it in the original carton with its packing materials because both the carton and packing material have been carefully designed to protect the unit.

Under normal conditions, no user maintenance or calibration is required. Internal links and preset controls may be set to configure the unit during installation. Any service work required should be carried out by qualified service personnel only.

We can offer further product support through our worldwide network of approved dealers and service agents.

To help us provide the most efficient service please would you keep a record of the unit serial number and date and place of purchase to be quoted in any communication regarding this product.

The actual equipment Serial Number is indicated on the silver label stuck on the rear panel of the equipment closure.

Tools and Equipment Needed

Only standard technician tools are required to install this equipment.

FIRST INSTALLATION RECOMMENDATIONS

POWER SUPPLY CABLE

A power supply cable of approx. 2 mt. lengths is supplied with the device, which has a moulded IEC plug attached – this is a legal requirement.

The type of plug for the power supply depends on the country in which it is delivered.

If for any reason, you need to use this appliance with a different plug, you should use the following wiring guidelines in replacing the existing plug with the new one:

Earth	Green, or green and yellow
Neutral (N)	Blue
Live (L)	Brown

Supply cables should be laid in such a manner that one does not step or walk on them. They should not be squashed by any objects.

THIS EQUIPMENT MUST BE EARTHED.

The chassis is always connected to mains earth to ensure your safety: check your mains wiring and earthing before switching on.

PROTECTION AGAINST LIGHTNING



Should the device be put out of action due to being struck by lightning or excess voltage, disconnect it from the power supply without delay. Do not reconnect until the device has been checked. If in doubt contact the technical support service.

Make sure there is suitable lightning protection to protect the device. Alternatively, you should disconnect all connectors from the device during a storm or when the device is going to be unsupervised or not used for a longer period.

These measures will protect against damage by lightning or excess voltage.

INSTALLATION NOTE AND FIRST STEP

Best setup location

The console should be installed avoiding direct sunlight, close proximity to radiators and air conditioning, dust, water, and chemicals. Choose a console location that permits a clear view of the indicators on the device and ensures a sufficient heat dissipation of the device.

Power supply

The device is designed for operation with 100 to 240 VAC, 50 Hz to 60 Hz. Check the corresponding device labelling for compatibility with the domestic line voltage and frequency before connecting the IEC power connector to the mains supply!



WARNING

Disconnect the mains power plug before you open the housing. Repair of the equipment must only be carried out by authorized and qualified personnel.

Power Supply	Please make sure that the device and the contained fuse(s) (please see p. 17) are compatible with the domestic line voltage and frequency. If the device is compatible, connect the power supply cord fully to the IEC power connector at the rear side of the device and a mains power outlet. The “LCD Screen” will then turn on.
Network configuration	The table has a display, so you can configure the IP settings See step “LAN-1 PAGE FUNCTIONALITY (HOW TO SET THE TCP/IP ETH-1)”
Connect to network	Connect a network patch cable to the “10/100-Base-T” connector on the rear side of the device and your existing IP network.
Ready!	These first steps are only intended for a quick first start and do not cover all device functions. Please read carefully the entire manual to be able to use all functions of the device.

INTRODUCTION

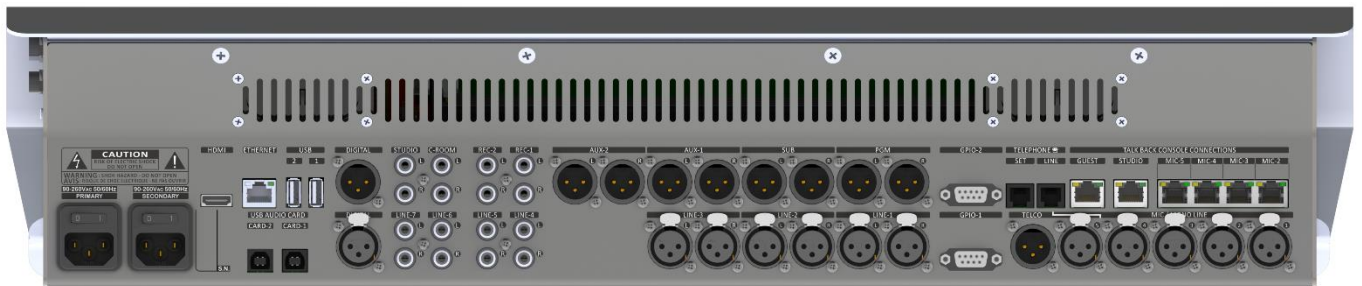

- The console is the new concept digital console and defines a new standard in the broadcast market.
- Characterized by an elegant design and compact size, the console has been designed for both On-Air and Production studios.
- The console is based on digital technology with DSP audio processing to deliver high-end quality, latest features, and flexibility with ease of use.
- The console is the number 1 in the category at the best quality/price ratio.
- The console is a powerful and compact unit featuring 10 faders, meters for every single channel, a built-in 7" display for settings, a wide range of connectivity, and accessories in a rugged and classy steel chassis. Easy and reliable as the analog mixing consoles,
- The console adds the value of the digital engine that grants a near 0 latency (< 0,7 ms I/O) and plenty of advanced functions as the internal routing signal, customizable pre-set and easy recall, user-defined smart keys, analog, and digital I/O.

1. GENERAL DESCRIPTION

1.1 MIXER DIMENSIONS

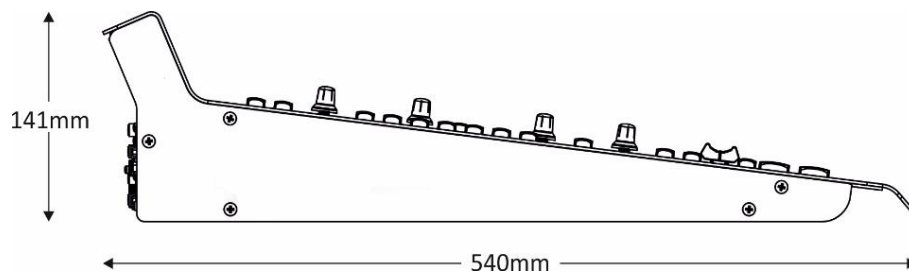
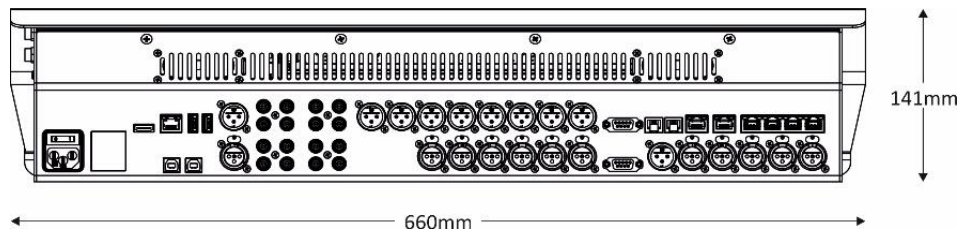
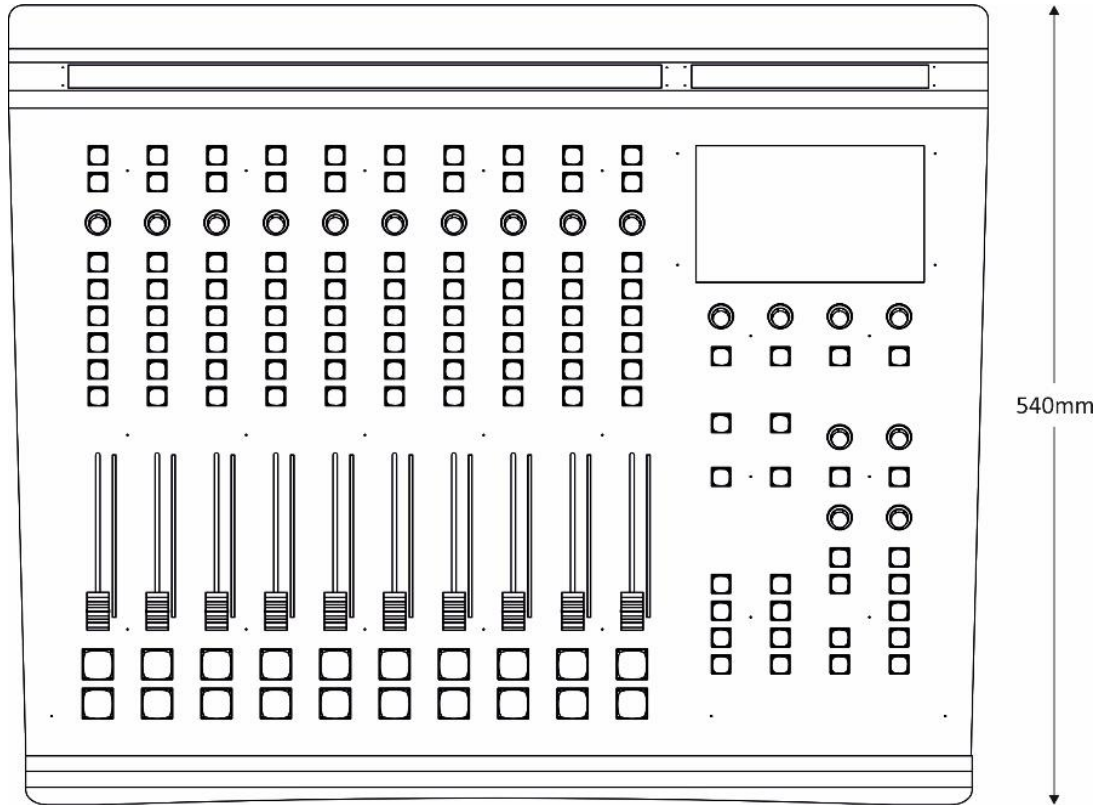

1.2 CUTTING TEMPLATE

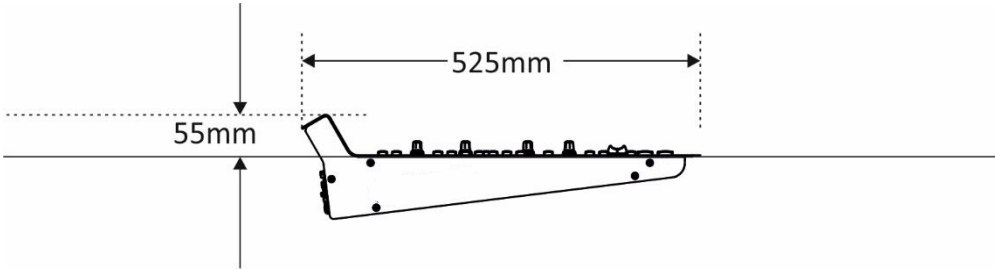
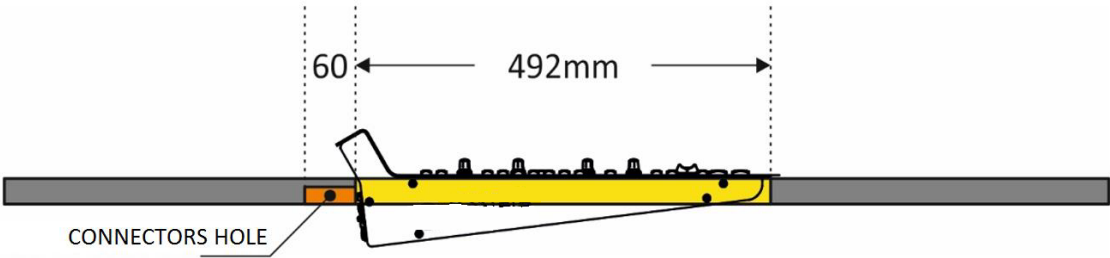
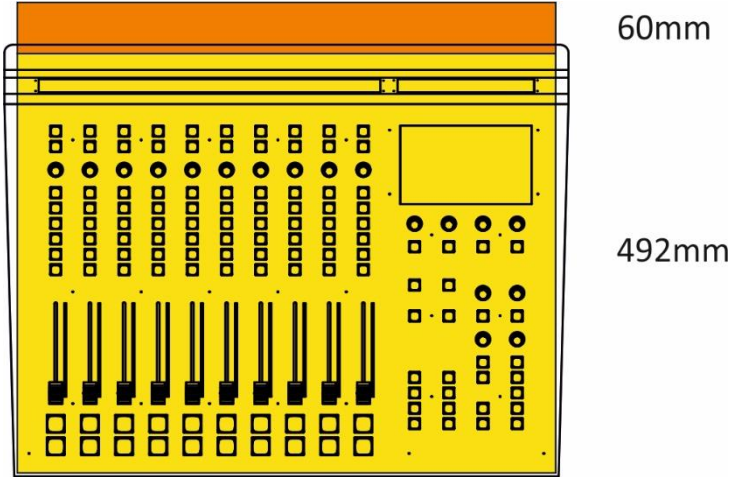
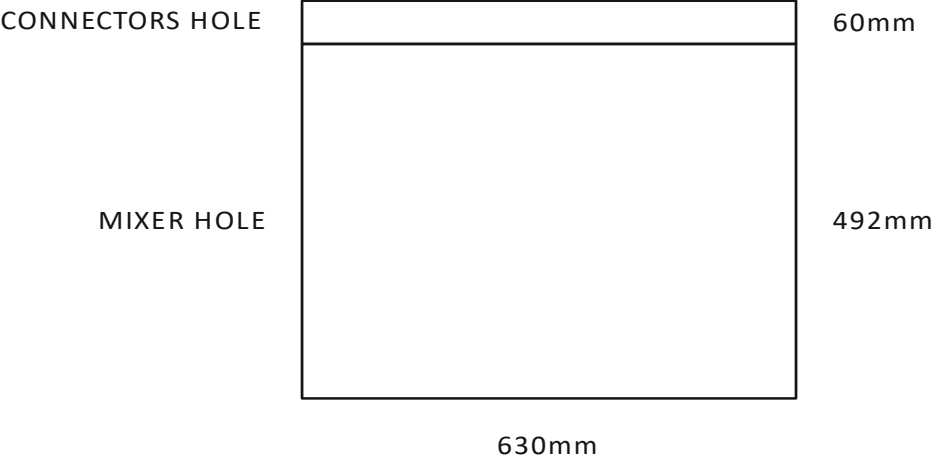

1.3 TALKBOX DIMENSIONS

TOP

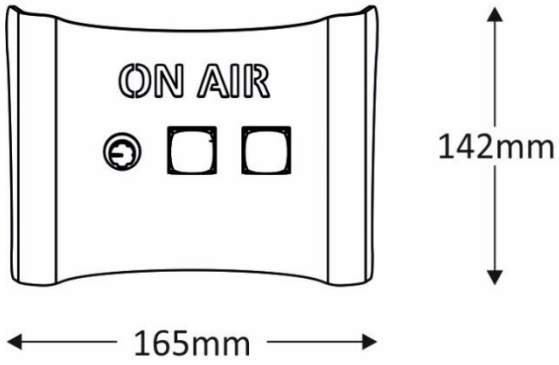

SIDE

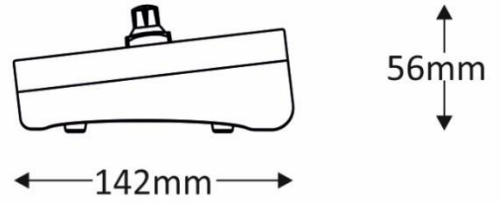

FRONT

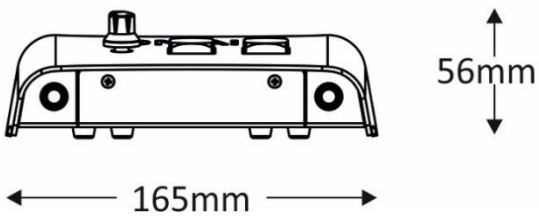

REAR

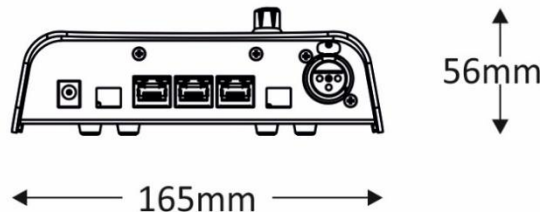

1.4 INPUT CONNECTIONS

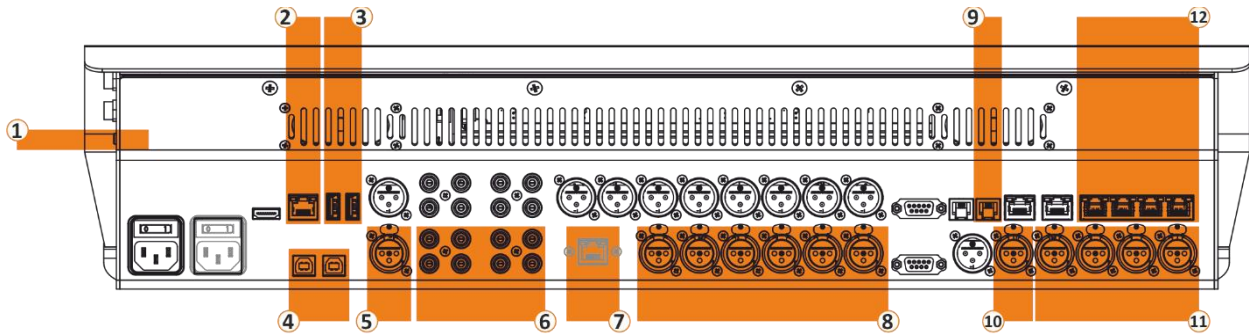

1. **Aux-In**
Stereo Input - Mini Jack 3.5mm - Unbalanced Audio Connection. (it will be out of service if the mixer contains the DANTE option)
2. **Ethernet Input**
RJ45 - Internet Connections.
3. **USB ports**
2 USB ports Type A for Export and import the mixer configurations. Import LOGO.
4. **USB-1, USB-2**
2 Audio Card Stereo Input- USB-Type B - PC Connections.
5. **Digital-In**
AES/EBU Stereo Input - XLR Female - Balanced Digital Connection (110Ω).
6. **Line-4, Line 5, Line-6, Line-7**(this is the EXT input for TUNER)
4 Stereo Input - PIN RCA - Unbalanced Audio Connection.
LINE-4 and LINE-5 are transformable to be **2 TELCO** per each.
7. **Bluetooth**
Bluetooth Stereo/Mono Input - Wireless – Smartphone.
LAN DANTE*
2 Stereo digital audio inputs over Ethernet.
8. **Line-1, Line-2, Line-3**
3 Stereo Input / 6 Mono - XLR Female - Balanced Audio Connection (10KΩ).
9. **Telephone**
Analog Telephone Line - RJ11 - PSTN Interface.
10. **Telco/Mic-5**
Mono/Mic Input - XLR Female - Balanced Audio Connection (1.2KΩ). It works as a LINE input. To use it as a normal MIC you have to amplify the MIC of +16 dB.
11. **Mic-1, Mic-2, Mic-3, Mic-4**
4 Mic Input - XLR Female - Balanced Audio Connection (1.2kΩ).
12. **TBox-2, TBox-3, TBox-4, TBox-5**
4 Talk Box Input - RJ45 (SFTP Cable) - Balanced Audio (Mic2/3/4/5 Input).

* Optional.

1.5 OUTPUT CONNECTIONS

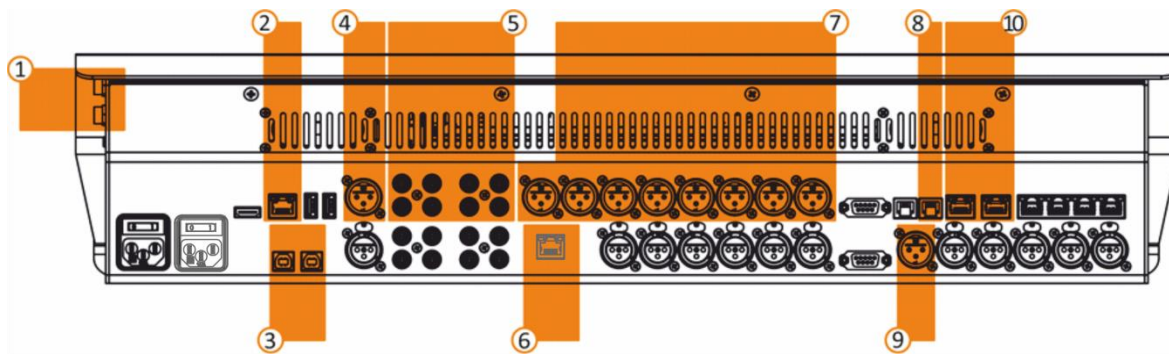

- 1. Headphones**
2 Line headphones output of Control Room and Studio.
Jack 6.3mm - Unbalanced Audio Connection (nominal 32 Ω).
- 2. Ethernet**
RJ45 - Internet Connections (online updates), Web interface, remote control, and monitoring.
- 3. USB-1, USB-2**
2 USB Audio Card USB -Type B - PC Connections.
- 4. Digital Out**
AES/EBU Stereo Output - XLR Male - Balanced Digital Connection (110 Ω).
- 5. REC-1, REC-2, SPK C-ROOM, SPK STUDIO**
4 Stereo Output - PIN RCA - Unbalanced Audio Connections (10k Ω).
- 6. LAN Dante***
2 Stereo digital audio inputs over Ethernet Dante™.
- 7. PGM, SUB, AUX-1, AUX-2**
4 Stereo Output - XLR Male - Balanced Audio Connection (23 Ω nominal (600 Ω)).
- 8. Telephone**
Analog Telephone Line - RJ11 - PSTN Interface.
- 9. Telco**
Mono Output - XLR Male - Balanced Audio Connection (23 Ω nominal (600 Ω)).
- 10. HDP-STUDIO, HDP-GUEST**
2 Talk Box Output - RJ45 (SFTP Cable) - Balanced Audio (Studio & Guest Headphone).

* Optional.

1.6 COMMUNICATION CONNECTORS

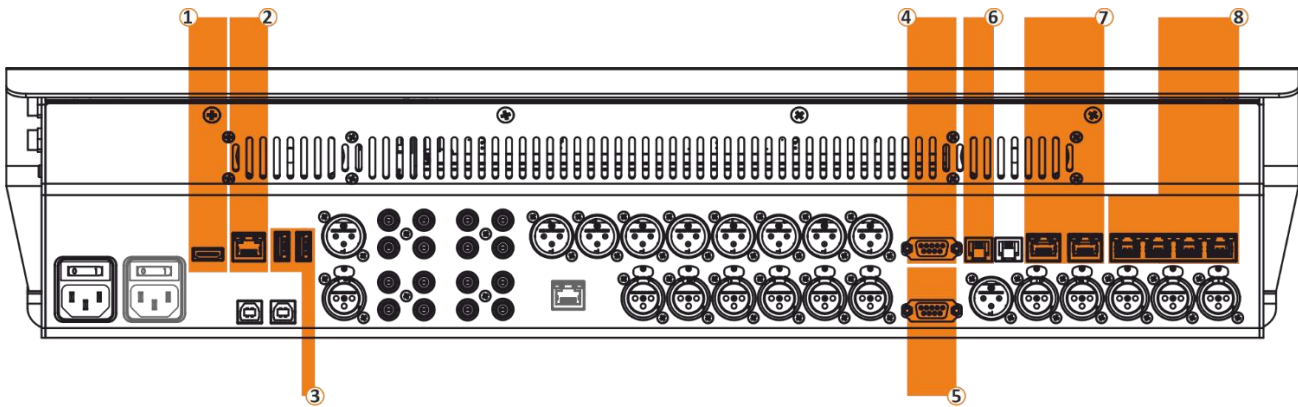

1. **HDMI Output**
Standard HDMI Female Connector - External Monitor.
2. **Ethernet**
RJ45 Female Connector - Internet Connections (online updates), Web interface, remote control, and monitoring.
3. **USB-1, USB-2**
Two USB Type-A Female ports for export/import the configurations and LOGO.
4. **GPIO-2**
SUB-D 9p Female - 2 GPI + 2 GPO.
5. **GPIO-1**
SUB-D 9p Female - 2 GPI + 2 GPO.
6. **Tel Set**
RJ11 (PSTN Interface).
7. **TBox-HDP-STUDIO, TBox-HDP-GUEST**
2 RJ45 (SFTP Cable) - n° 1 GPO Connection.
8. **TBox-MIC-2, TBox-MIC-3, TBox-MIC-4, TBox-MIC-5**
4 RJ45 (SFTP Cable) - n° 2 GPI Connections + n° 1 GPO Connection.

1.7 TALKBOX CONNECTIONS

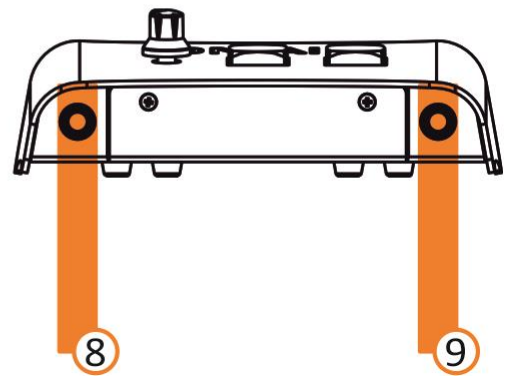
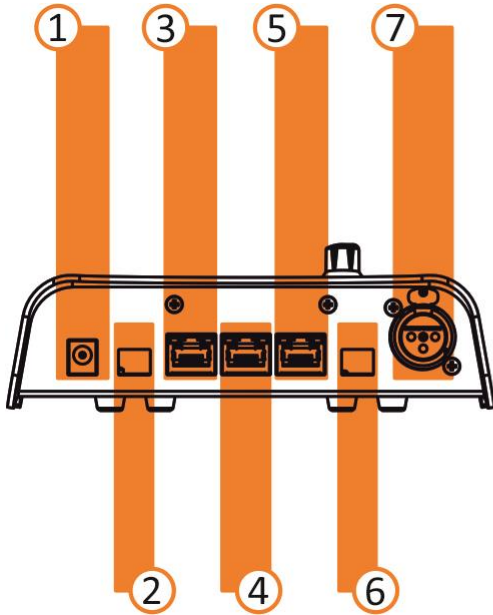

- 1. Power Supply**
12VDC 1A
- 2. Studio Light**
2 PIN Screw Connector - (12VDC output).
- 3. HDP Output**
RJ45 Connectors (SFTP) - (Passive Loop Output).
- 4. HDP Input**
RJ45 Connectors (SFTP).
- 5. Talk Box Connection**
RJ45 Connectors (SFTP) - (Passive Loop Output).
- 6. Mic Light**
2 PIN Screw Connector - (12VDC output).
- 7. Mic Input**
XLR Female Connector.
- 8. HDP-1-TBox**
Jack 6.3mm Female Connector - (Min. Imp. 32Ω).
- 9. HDP-2-TBox**
Jack 6.3mm Female Connector - (Min. Imp. 32Ω).

2. SURFACE

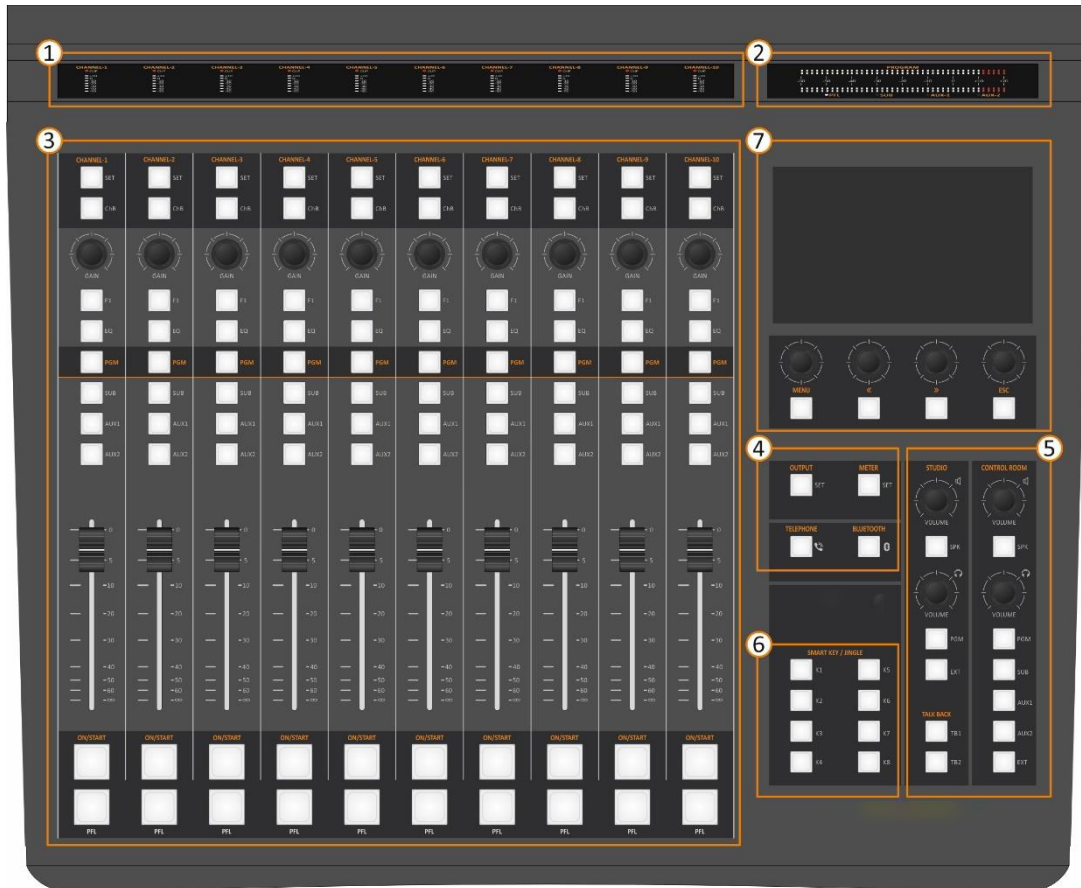

1. INPUT LED METER
2. OUTPUT LED METER
3. CONTROL INPUT CHANNEL
4. SPECIAL FUNCTION BUTTONS
5. MONITORS SECTION
6. SMART KEY / JINGLE BUTTONS
7. DISPLAY 7" TFT AND CONTROL BUTTONS

2.1 INPUTS LED METER

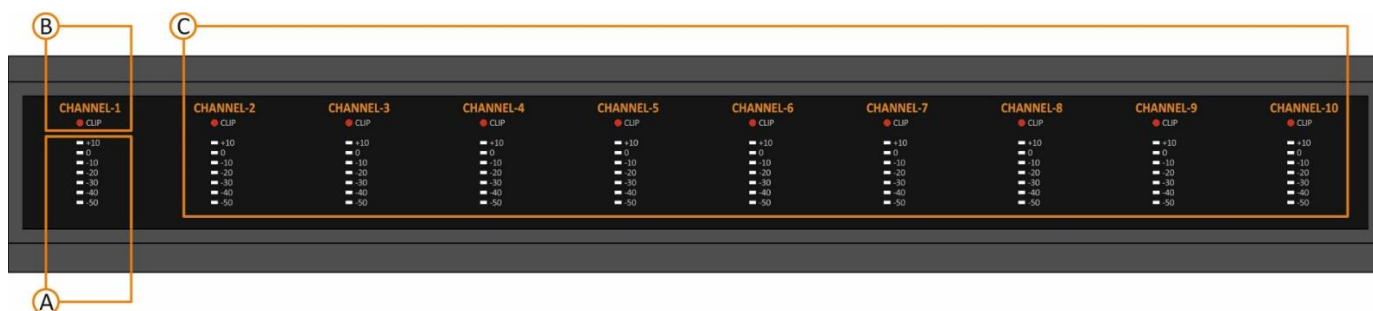

- A. The LED level meters display the audio signal input on the channel (PRE-FADER).
The LED level meters have a 10dB accuracy, from -50 to +10dB.
The level is PRE- FADER, the FADER position has no effect on the displayed level.
- B. CLIP LED
The lighting of the LED indicates the source level is too high.
This condition saturates the signal and creates audio distortions.
ACTION TO BE TAKEN: decrease the audio level from the source.
- C. Sources level meters PER-FADER and clip LEDs of the 10 channels.

2.2 OUTPUT LED METER

- A. LEDs Meter of the Program output signal (PGM).
The LEDs Meter have an accuracy of 2dB, from -60 to +20dB.
The level is POST-FADER.
- B. LED Meter of the signal of the output PFL/SUB/AUX-1/AUX-2/MONITORSELECTION.
The LED Meter has an accuracy of 2dB, from -60 to +20dB.
The level is POST-GAIN.

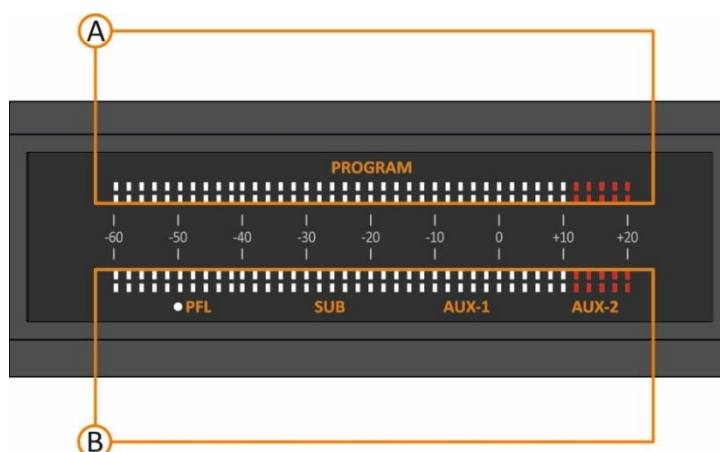

- C. It is possible to select the displayed **BUS** by pressing the **METER** button. It is possible to switch the 4 Buses and MONITOR SELECTION sequentially, by a repeated pressing.

PFL -> SUB -> AUX-1 -> AUX-2 -> MONITOR SELECTION -> PFL -> SUB...

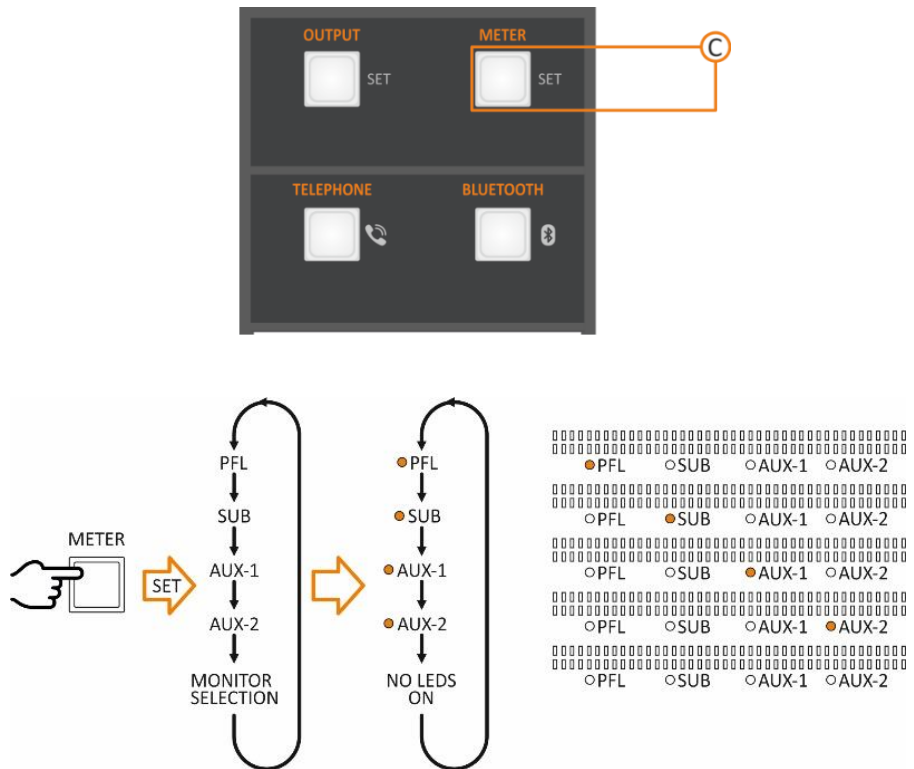

The selected **BUS** is forcedly displayed when the related LED (PFL/SUB/AUX-1/AUX-2) is on.

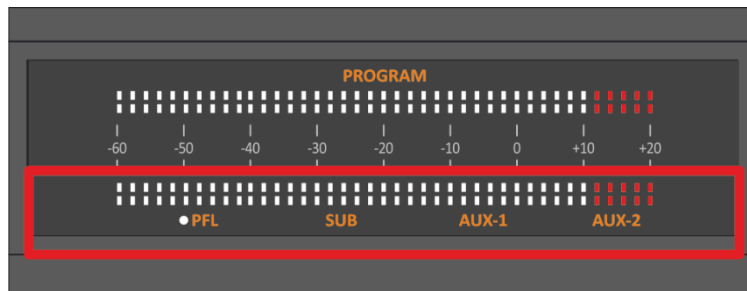

The 4 LEDs are off in the MONITOR SELECTION position. The displayed signal is the source selected in **HDP C-ROOM**, as shown in the following picture.

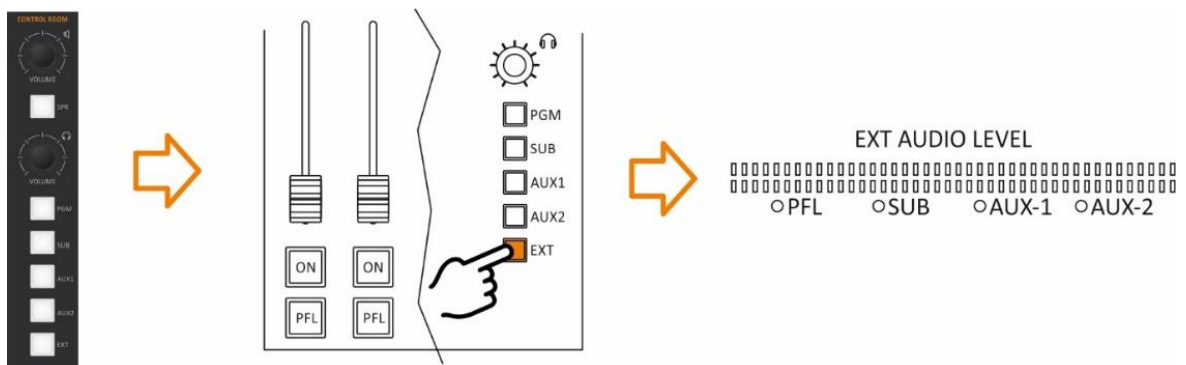

2.3 CONTROL INPUT CHANNEL

- A. SET – BUTTON TO SET CHANNEL PARAMETERS.
- B. CHB – BUTTON FOR THE SOURCE SWITCHING BETWEEN THE PRIMARY SOURCE (A) AND THE SECONDARY (B).
- C. GAIN – KNOB TO ADJUST THE INPUT SOURCE LEVEL OF THE SIGNAL.
- D. F1 – BUTTON TO ENABLE/DISABLE THE ASSOCIATED FUNCTION (Telephone / Telco).
- E. EQ – BUTTON TO ENABLE OR TO SET THE EQUALIZER.
- F. PGM – BUTTON TO ENABLE THE PGM BUS.
SUB – BUTTON TO ENABLE THE SUB BUS.
AUX-1 – BUTTON TO ENABLE THE AUX-1 BUS.
AUX-2 – BUTTON TO ENABLE THE AUX-2 BUS.
- G. FADER – THE FADER ALLOWS THE SOURCE LEVEL ATTENUATION.
- H. FADER LED BAR – IT INDICATES THE ATTENUATION AND THE SOURCE TYPE.
- I. ON/START – BUTTON TO SWITCH ON/OFF THE SELECTED SOURCE.
- J. PFL – BUTTON TO ENABLE THE PFL BUS.

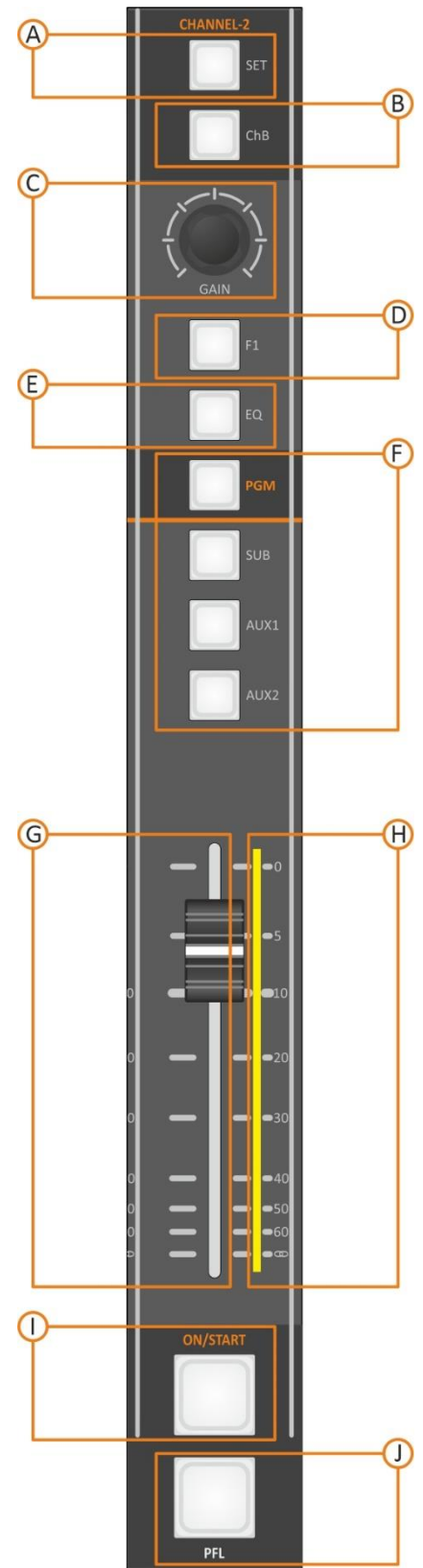

A. SET BUTTON

To enter in the settings menu and view the channel configuration, press **SET**.
single-clicking: the button starts blinking and shows on the display the configuration menu for the channel.

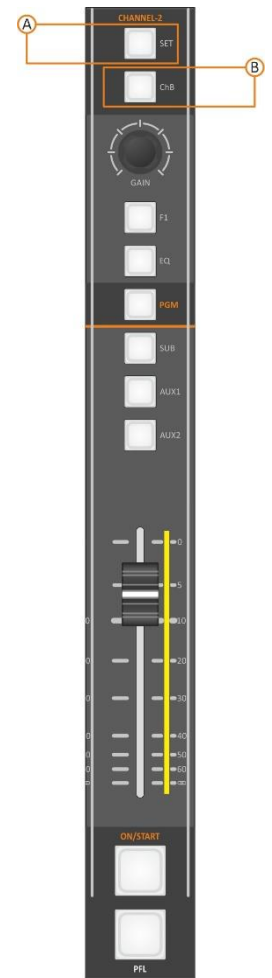

To exit from viewing/setting mode press one of the buttons: (**SET**, **MENU**, or **ESC**).

B. ChB BUTTON

For every channel, you can set two different input sources, **ChA** and **ChB**.
 By pressing **the ChB** button, you can switch over between **A/B** sources.

Button in **OFF** position: the **ChA** is active.

Button in **ON** position: the **ChB** is shown. The button starts lighting.

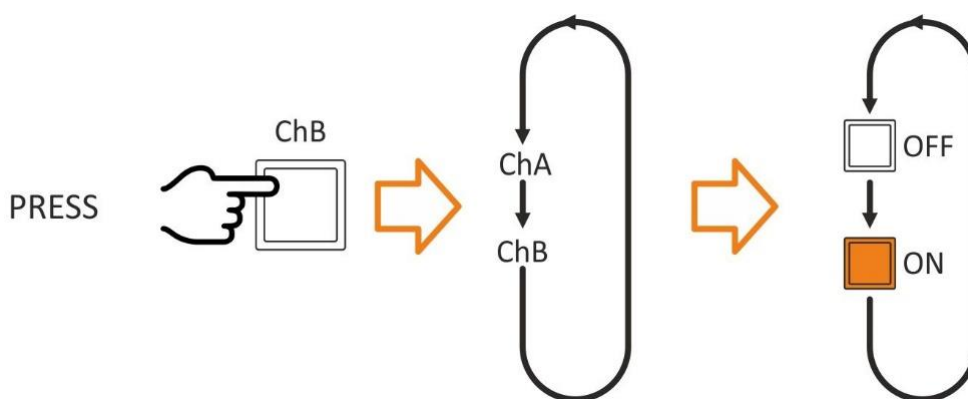

ATTENTION: If the source is already aired on another channel it is aired to the last one too. The faders will be added accordingly with the **BUS** selection.
 If Channel **B** is aired you cannot assign to it the **EMPTY** source.

C. GAIN

The **GAIN** knob rotation increases or decreases the input source gain.

The **GAIN** value is associated with the selected source **ChA/ChB**, not with the physical channel.

By switching the source, the gain is always suitable to the connected one.

The **GAIN** value is the latest setting is seated by the knob.

The **GAIN** affects the input level with **+/- 20 dB**.

Rotate a **GAIN** knob, it's will active the **SET** mode and shows the setting and **GAIN** level at the display.

The step of the **GAIN** adjustment knob is **0.1 dB**.

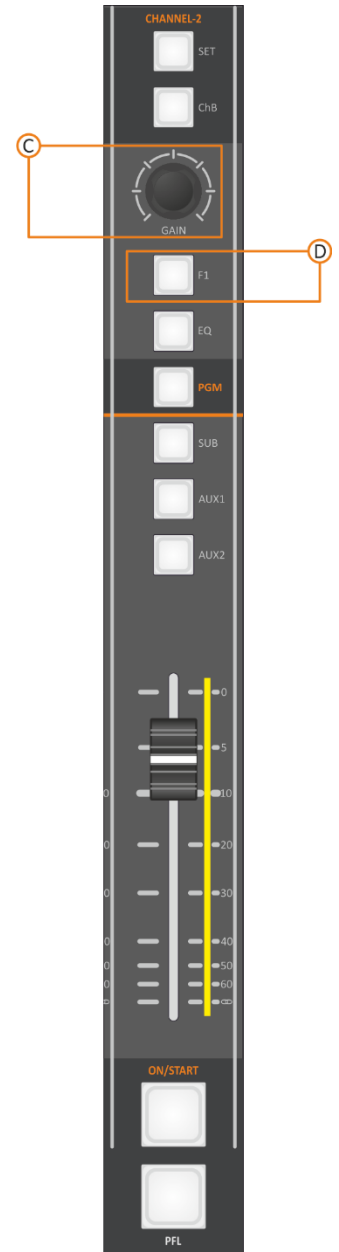
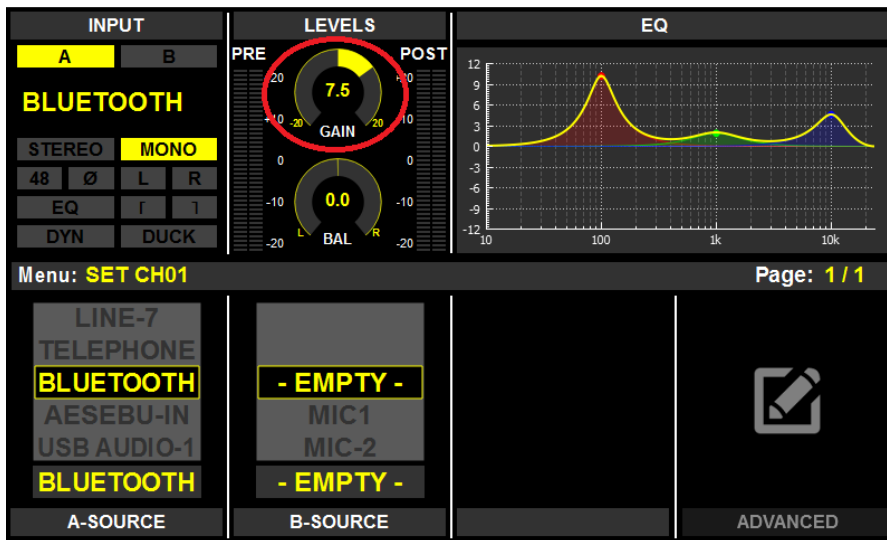

D. F1 BUTTON

Telephone Channel / Telco (Default Setting).

In the presence of an incoming call, the **F1** button starts blinking, By pressing **F1** it will hook the call.

- **F1** LED off – the line is not hooked.
- **F1** LED blinks – RING – there is an incoming call.
- **F1** LED on – the line is hooked.

By pressing **F1** again you drop the line.

Incoming call



PRESS THE BUTTON



Hooked



E. EQ BUTTON

The equalizer is associated with the selected source when a source is selected for a channel also the related and customized equalization is loaded.

Press **EQ** Enable/Disable the equalizer.

EQ button reports if the equalizer is ON or OFF by lighting.

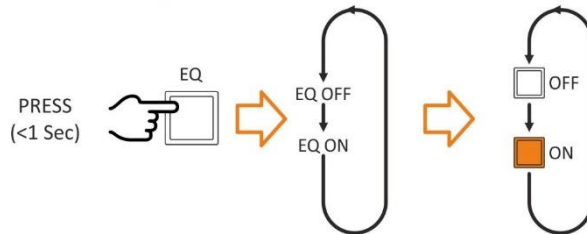

Press & Hold **EQ** Button to entering in the equalizer configuration menu “the **EQ** editor on the display”. It’s possible to change **BASS/MID/HIGH** equalizations. It’s also able to adjust from the advanced settings “**ADV. SET**” an equalizer like (LOW CUT, BASS, BASS-MID, MID, MID-HIGH, HIGH, HI-CUT).

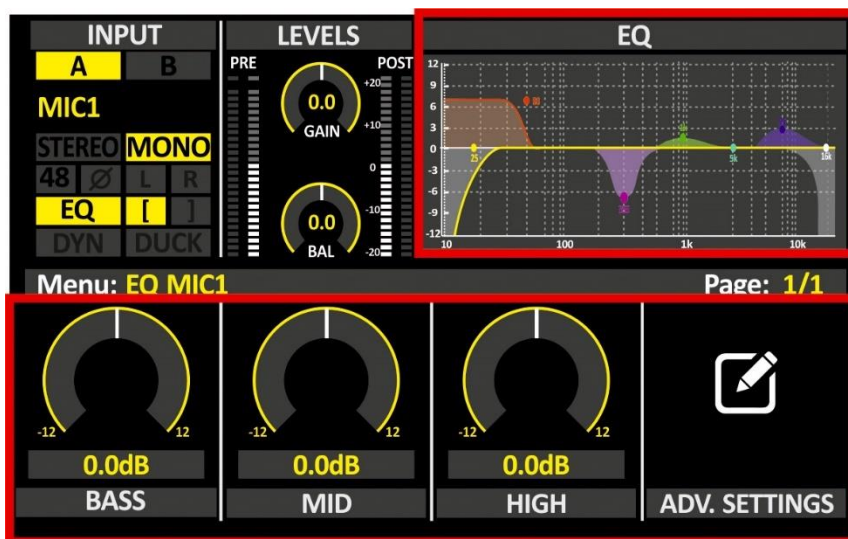
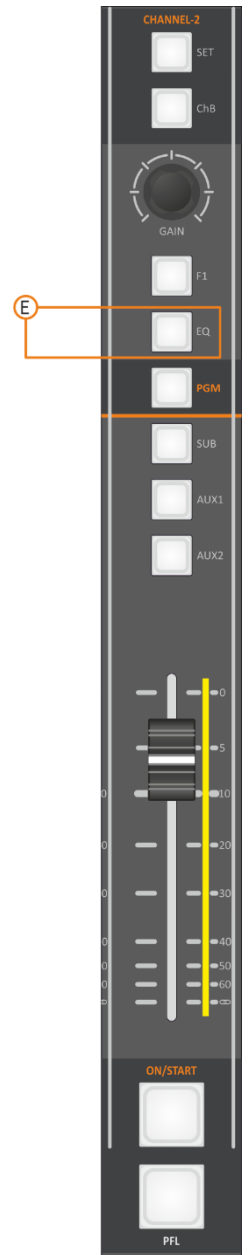
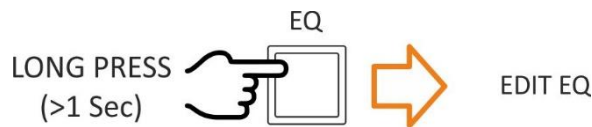

F. PGM/SUB/AUX-1/AUX-2 BUTTONS

The **PGM**, **SUB**, **AUX-1**, **AUX-2** buttons enable or disable the output signal routing on the related **BUS**, the RGB LEDs under the related button has three different states color:

- 1) disabled (LED OFF)
- 2) enabled + Channel ON
- 3) enabled + Channel MUTE

The Different in **BUS**'s status, it's not associated with the source, like **EQ** and **GAIN** but with the physical channel. when you changing the source, the **BUS**'s status will not change.

It's possible to set **AUX-1** and **AUX-2** to be **POST-Fader**, **PRE-Fader**, or **PRE-FADER ALWAYS ON**. This choice is settable in the settings menu of every channel's input source.

When a channel switches from ON to OFF or standby status, the related LEDs switches from ON Colour to standby color. this function allows us to understand the channel and BUS's status.

ON/OFF channel status could depend on:

- ON/OFF of ON/START button.
- Fader position.

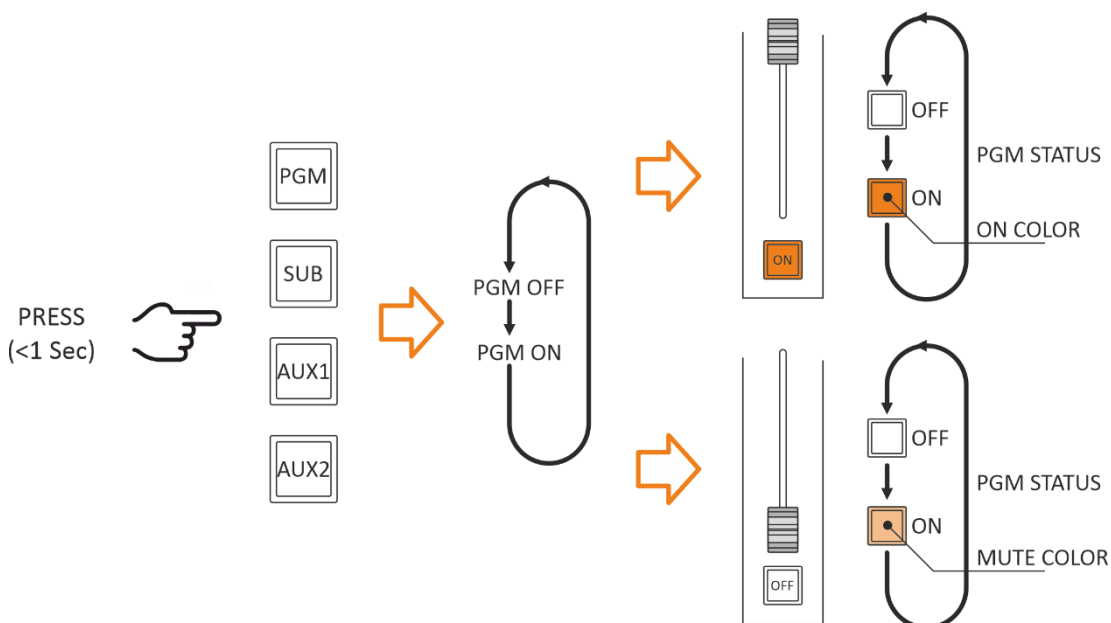
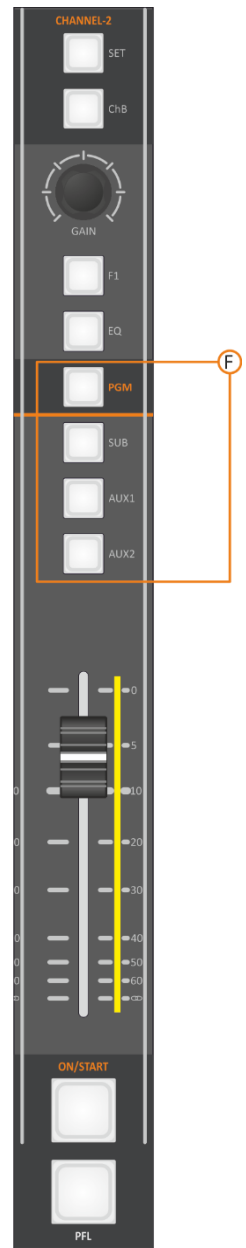

G. FADER

A command is generated every time the Fader passes through the threshold value:

ON - crossing the threshold point from bottom to top.

OFF - crossing the threshold point from top to bottom.

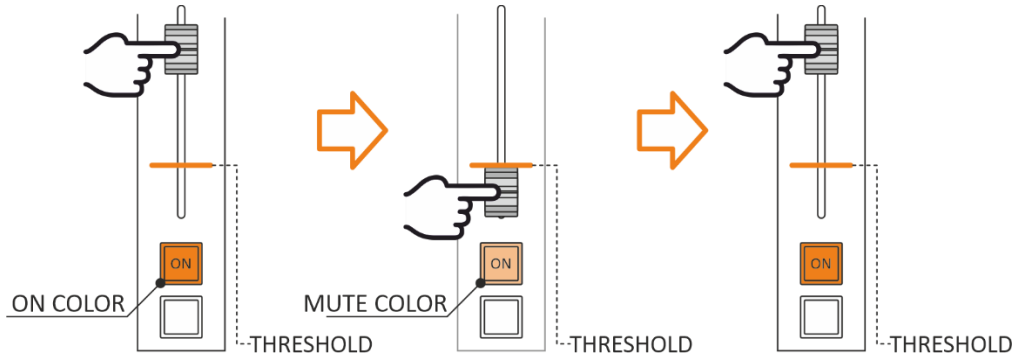

Differently, from the **EQ** and the **GAIN**, the **FADER** status is not associated with the source, it is associated but with the physical channel. Changing the source, the **FADER** attenuation and the **FADER** position will not change.

MOTORIZED FADER (Optional).

ATTENTION:

It is possible to set **AUX-1** and **AUX-2** to be **POST-Fader** or **PRE-Fader**.

The **FADER** does not affect the signal in the **PRE-FADER** case.

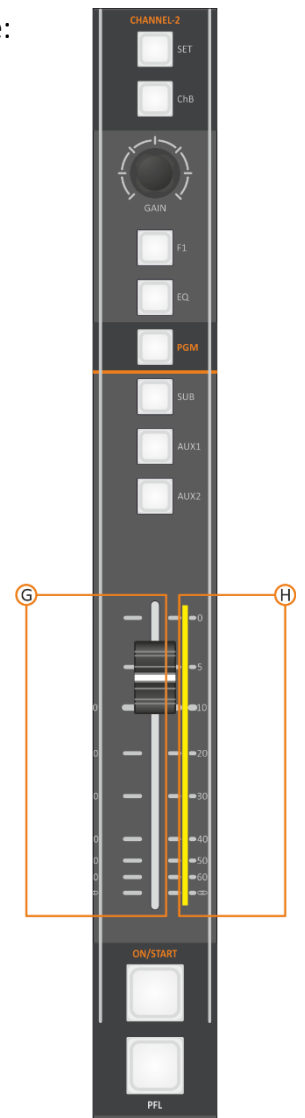

H. FADER LED BAR

The **FADER** LEDs BAR shows the channel level.

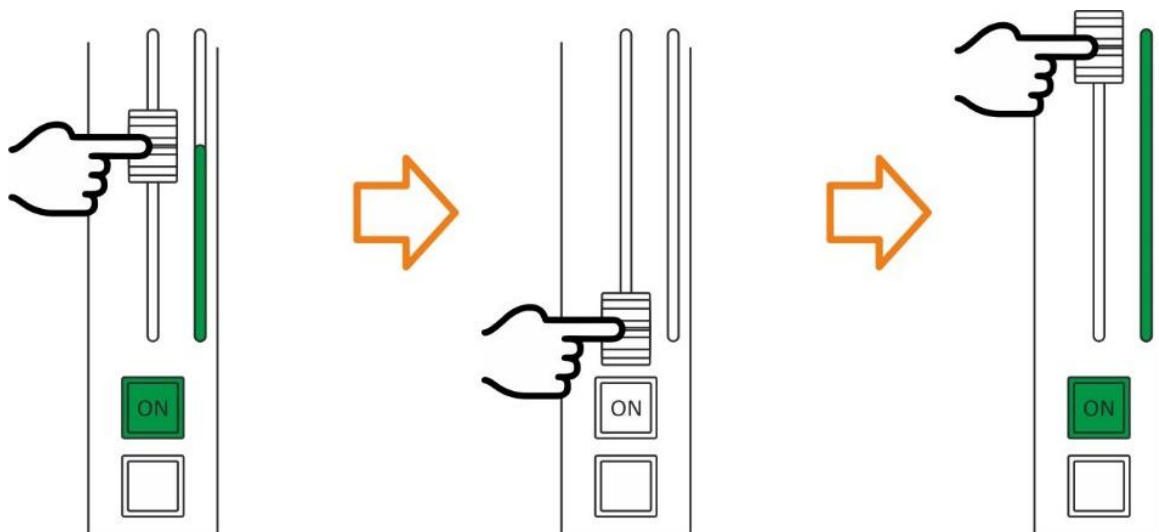

I. ON/START BUTTON

ON/START button enable or disable the channel (ON/OFF), the OFF status mutes the channel automatically, and the RGB LEDs under the buttons has three different statuses:

- 1) **LED OFF** - OFF status - the channel is MUTE.
- 2) **LED ON** in (warm color) - ON status – the channel is OPEN.
- 3) **LED ON** in (light color) – standby status.

Differently, from the **EQ** and the **GAIN**, the **ON/OFF** status is not associated with the source, it's associated with the physical channel. It's unable to changing the sources between (**ChA/ChB**) if the channel status is **ON**.

The **ON/OFF** channel status could be changed by:

- pressing at **ON/START** button as shown below.

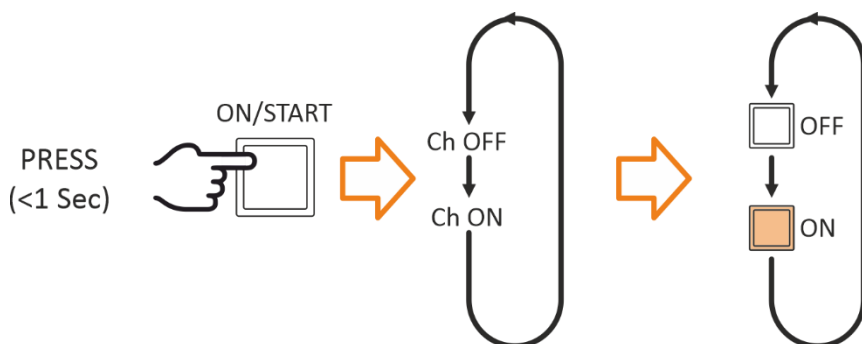

- The passage of the fader through a previously set threshold value.

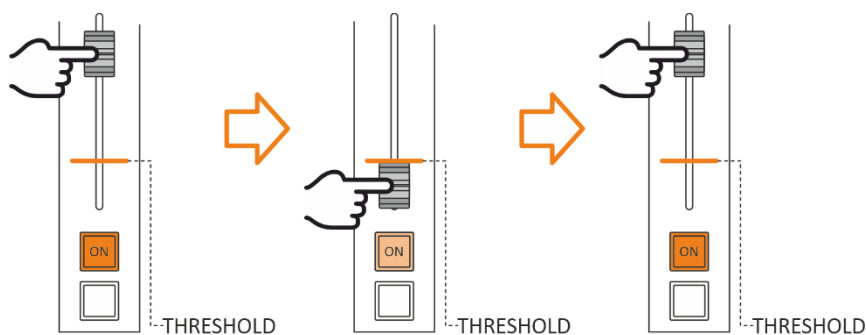

In the case of ON BY FADER active, it is possible to combine the FADER action with the ON/START button.

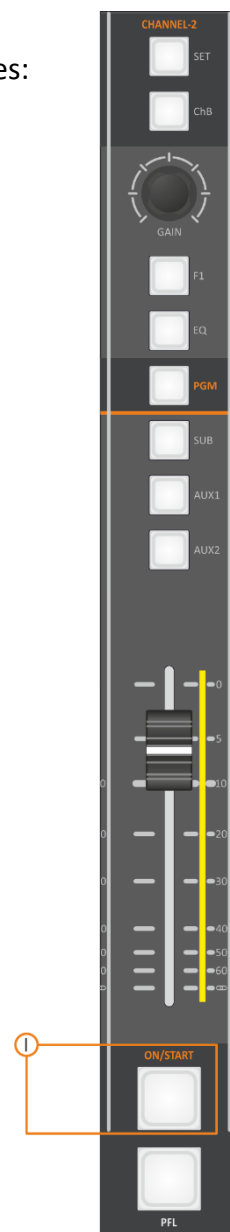
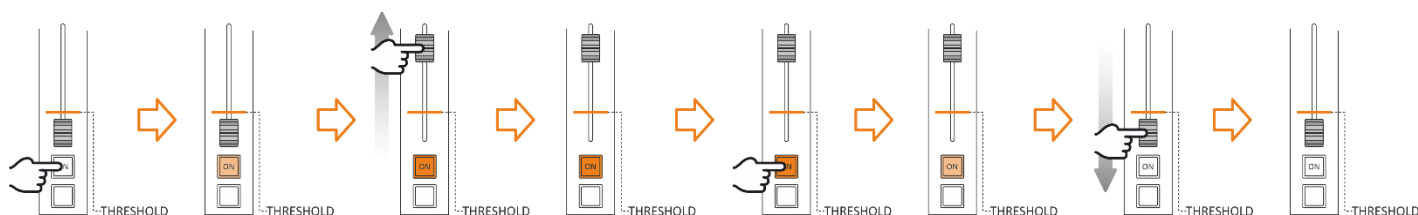

- OFF
- ON
- MUTE

J. PFL BUTTON

PFL button enables/disables the **pre-listen** of the channel. When the button's LED is ON, the pre-listen is enabled on that channel.

Differently, from the **EQ** and **GAIN** the **PFL** status is not associated with the source, it's associated with the physical channel. Changing the source, the **PFL** status will not change.

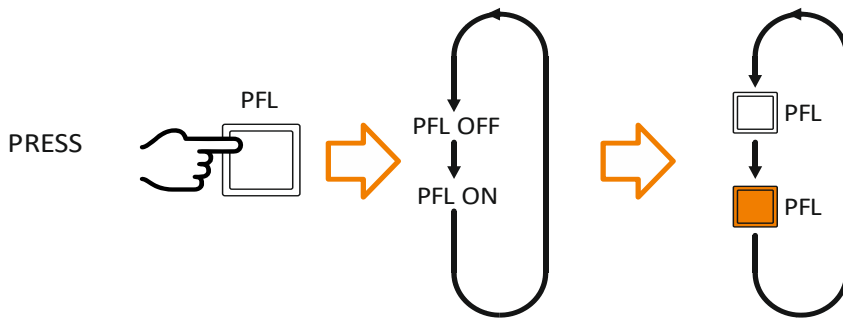

By pressing an enabled **PFL** you will disable it from the MONITOR pre-listening. **PFL**, its effect appears on any of the monitor (headphone or speakers) if that monitor mode is **+PFL**, like (**SEL+PFL**, **1SEL+PFL** or **2SEL+PFL**).

For example:

To active PFL in Control Room speakers (**SPK-CRM**), follow up this path to change the mode to **+PFL**

MENU / AUDIO / OUTPUTS / MONITOR / SPEAKER / SPK-CRM / MODE
(1SEL+PFL, 2SEL+PFL)

By going to **MAIN / AUDIO / SETTINGS** can change the **PFL MODE** between **SINGLE PFL** and **SUM PFL**.

SINGLE PFL: Allowed to select/listen to only one PFL per time.

SUM PFL: Allowed to select many PFL and listening to them all at the same time.

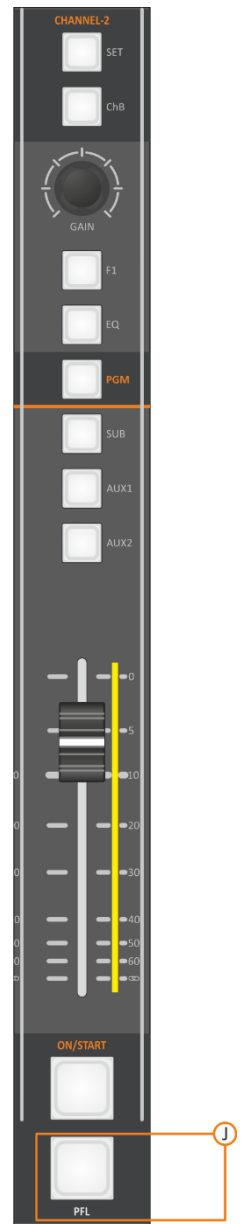
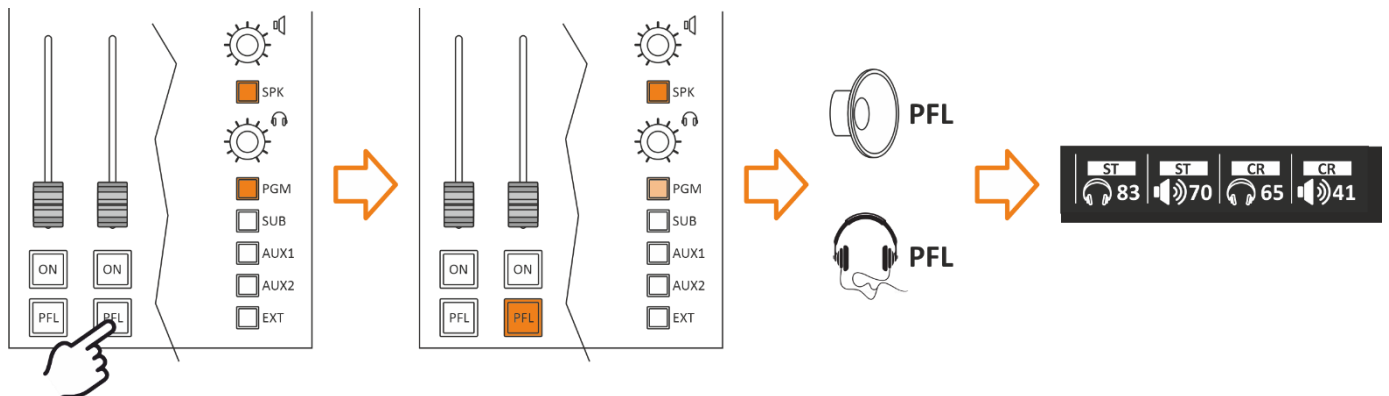

2.4 SPECIAL FUNCTION BUTTONS

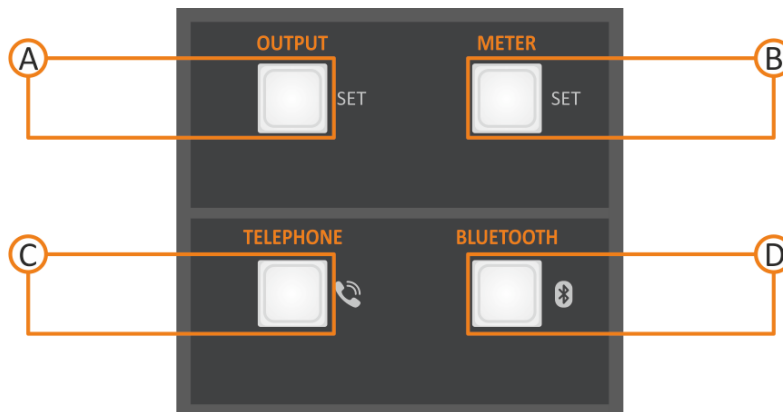

A. OUTPUT BUTTON

The **OUTPUT** button recalls directly the **OUTPUTS** configuration menu. This button is a SHORTCUT to reach immediately the OUTPUT menu.

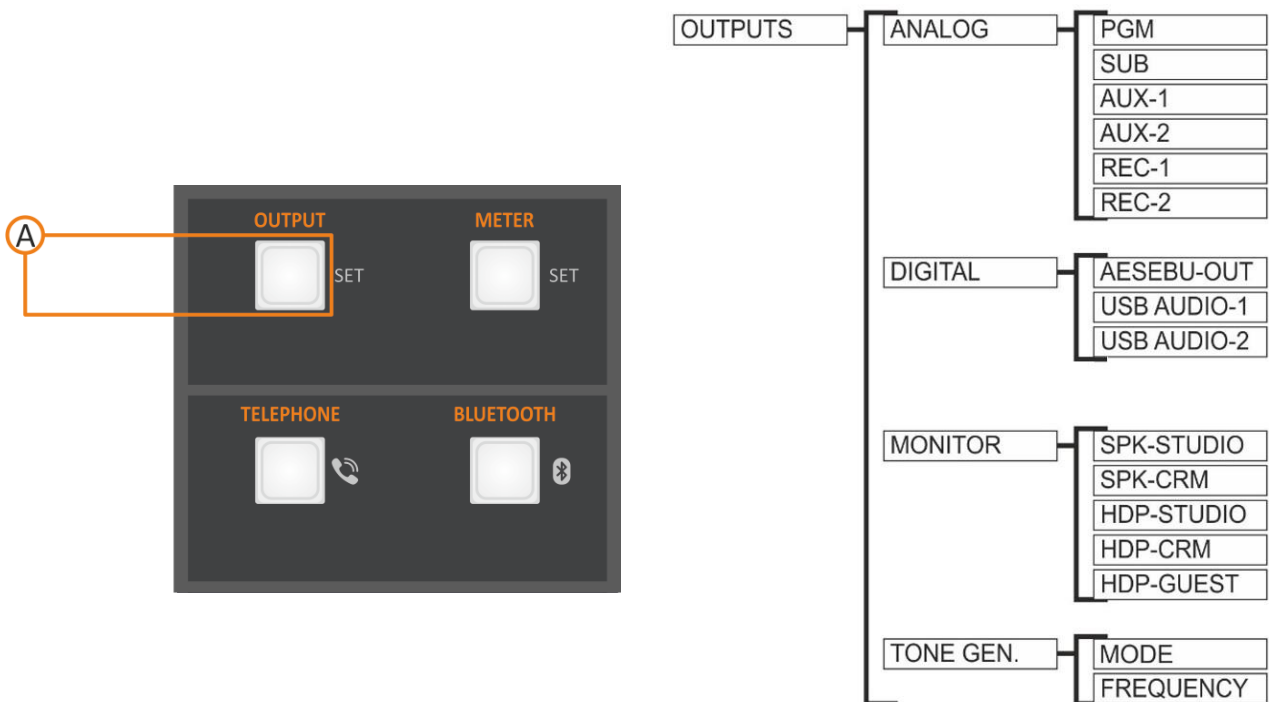

B. METER BUTTON

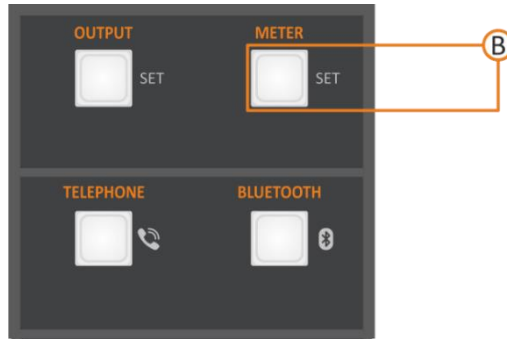

The **METER** button manages the source displayed in the bottom section of the LED METER screen. By pressing **METER**, you can select the displayed **BUS**.

The repeated pressing of the **METER** button switches the 4 **BUS** and the MONITOR SELECTION, sequentially displaying them.

PFL -> SUB -> AUX-1 -> AUX-2 -> MONITOR SELECTION -> PFL -> SUB

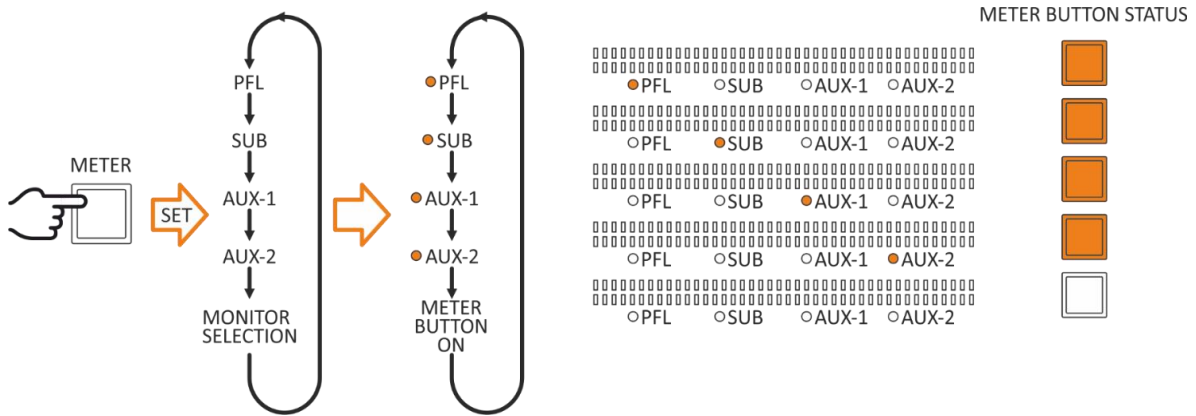

If one of the four LEDs is on (PFL/SUB/AUX-1/AUX-2) the selected **BUS** is forcibly displayed.

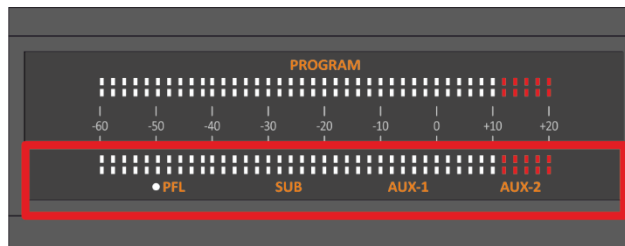

The selected source in **HDP C-ROOM** is being displayed in the MONITOR SELECTION status. In this case, all 4 LEDs are OFF as explained in the following picture.

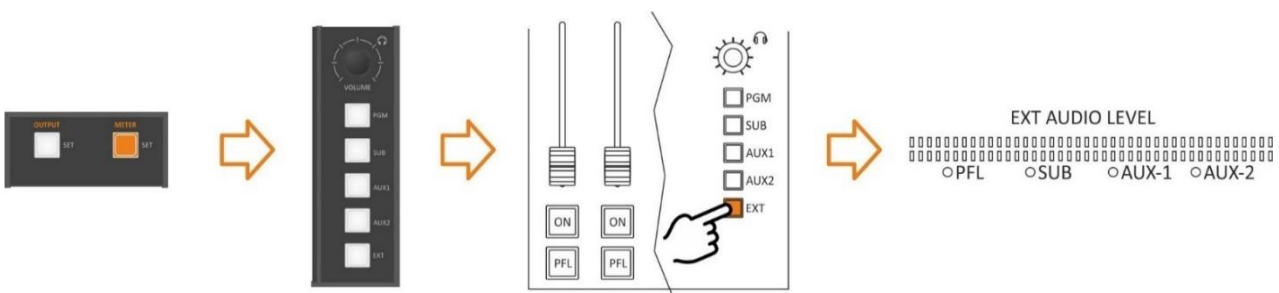

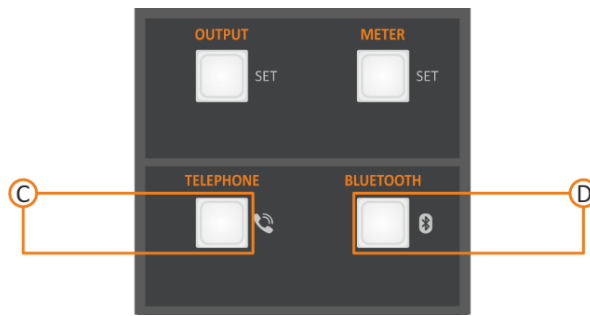

C. TELEPHONE

This button has the same functionality as the button F1 in the telephone channel. From here can hook up the incoming call from the telephone line channel (built-in hybrid).

D. BLUETOOTH

The Bluetooth has two functioning ways:

- Microphone **TX**(Mono)- **RX**(Mono) Interface for telephone communication (GSM call, Skype, FaceTime, WhatsApp, Facebook, Etc.)
- **RX** (Stereo) interface for file/streaming player...

The device is in pairing mode after a fast press (< 1 sec) of the Bluetooth button. It starts to blink in blue color.



search for the **console** in Bluetooth device and connect with it. Once the device is connected the blue light stops blinking.



Press the desired **SET** button and search for Bluetooth in the source menu (for example SET button of the 4th channel).



Press the desired **BUS** on the channel (in example PGM).



start the audio streaming (music, audio from YouTube/Music Player) or the phone call (Call, Skype, WhatsApp,) from the Bluetooth device.





With a long press of the Bluetooth button, you will disconnect the device.

If you turn on again the Bluetooth in the device and if the device is still associated with the console, it will be automatically paired. You will see a fixed blue light. The console is included **RN52 Bluetooth Audio Module**.

2.5 MONITORS SECTION

A. CONTROL ROOM SPEAKERS (SPK-CRM)

- This section is used for the management of the **Control Room Speakers**.
- The rotary control knobs allow you to **amplify/attenuate** the audio level.
- The loudspeakers audio level goes from **0** to **99** is the maximum allowed level. Can set the maximum level by going to this page: **MENU / AUDIO / OUTPUTS / MONITOR / SPEAKER / SPK-CRM**
- The step of the loudspeaker adjustment is **1 dB** and the level goes from **-80 dB** to the maximum of **+19 dB**.
- By **pressing the knob**, you can mute  or play the control room speakers if it is already muted.
- To unmute the speaker  just press their knob or **increase/decrease** the audio level by rotating the knob and confirm that by clicking on the same knob.
- The Control Room Speaker's level is displayed in the bottom-right section of LCD.

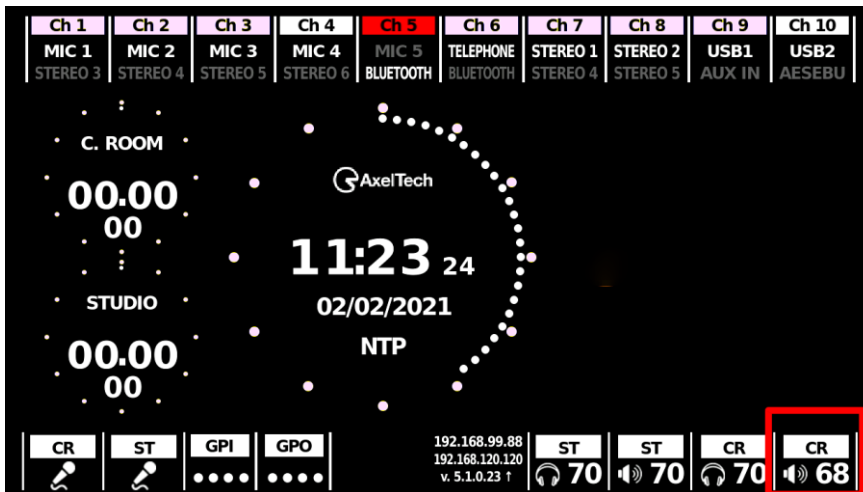
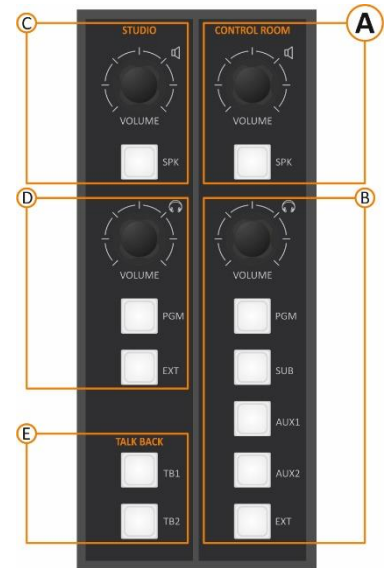



MODE: 1SEL, 1SEL+PFL, 2SEL or 2SEL+PFL

MENU / AUDIO / OUTPUTS / MONITOR / SPEAKER / SPK-CRM / MODE

PFL (pre-fader listening): This mode allows you to listen in speakers to the audio of the single-channel **before** the intervention of the fader.

1SEL (one selection): This option allows you to listen in speakers to only ONE selected output from output section  (PGM, SUB, AUX1, AUX2, EXT).

1SEL+PFL: This mode allows you to listen to **ONE selected output** or **PFL** if press the button  PFL of one channel.

2SEL (two selection): This option allows you to listen to ONE selected output  (PGM, SUB, AUX1, AUX2, EXT), And by pressing the **SPK** button  you will be able to listen to different output in speakers.

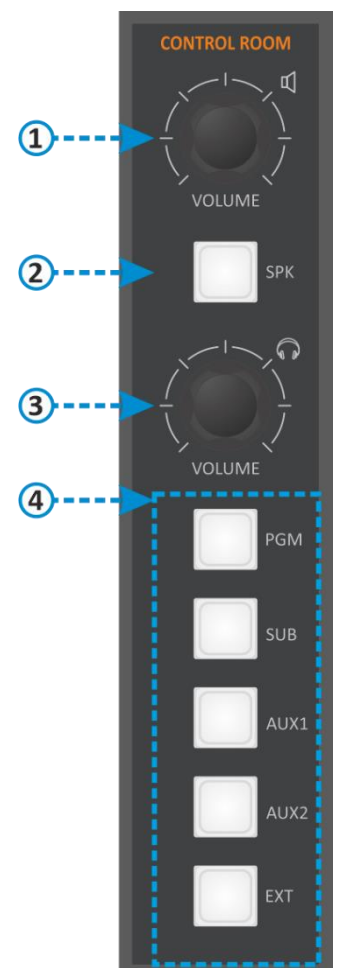

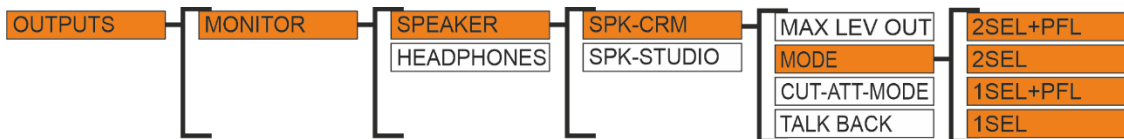

EX.: if you need to listen to different output in **SPK-CRM** Control Room Speakers, select the **2SEL** mode from the setting and press the **SPK** button in section ② (it will show up in warm color), then press any other output button from section ④ (it will show up in warm color) to hear that output in the speakers only. (see the next figure).

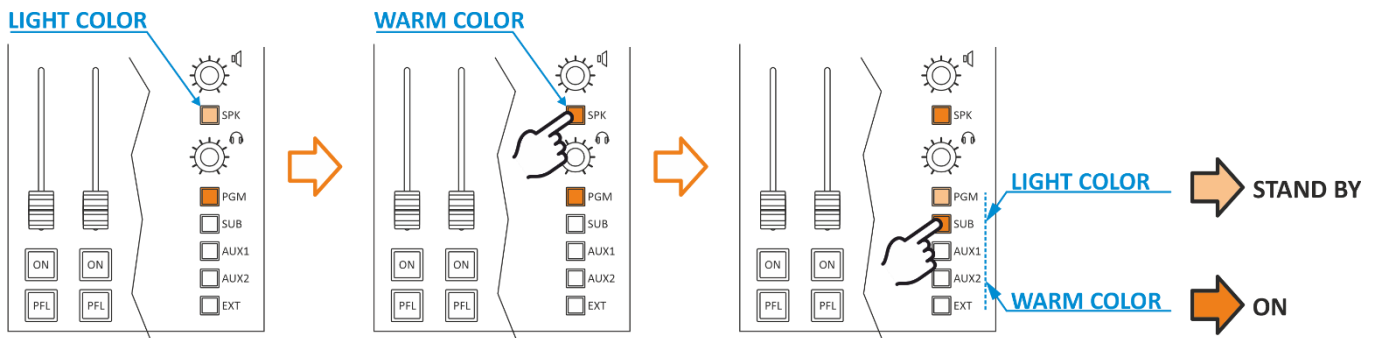

2SEL+PFL: It is a similar mode to the above-mentioned case, in addition to that you can hear the **PFL** in a bout of headphones and speakers simultaneously. (see the next figure).

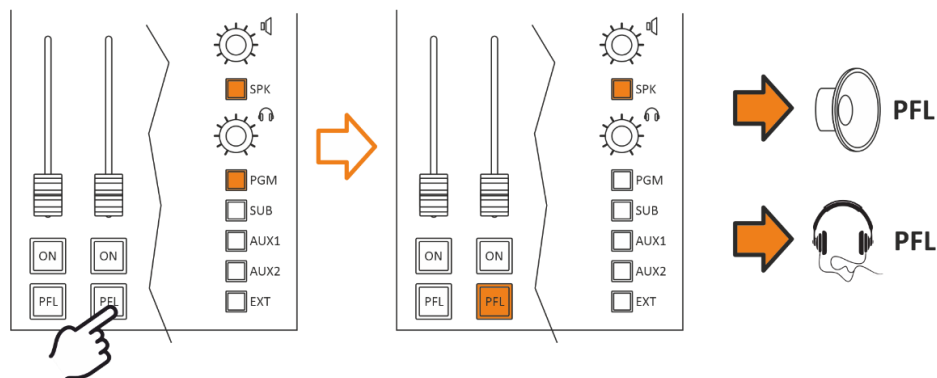

CUT-ATT-MODE

MENU / AUDIO / OUTPUTS / MONITOR / SPEAKER / SPK-CRM / CUT-ATT-MODE

CUT MODE: it's allowed the microphone to **CUT OFF** the audio of control room loudspeakers once the microphone goes to ON.

The opening of a microphone channel (if configured appropriately) can generate the closing command of the loudspeakers.

That is possible to choose one or more microphone to cut the loudspeaker output of the **CR** "Control Room" by following this path:

MENU / AUDIO / INPUTS / MIC / SPK-CUT (OFF, ST, CR, CR+ST)

When you select **CR**, press down the knob to confirm the selection and the **CR** will show up in yellow color.

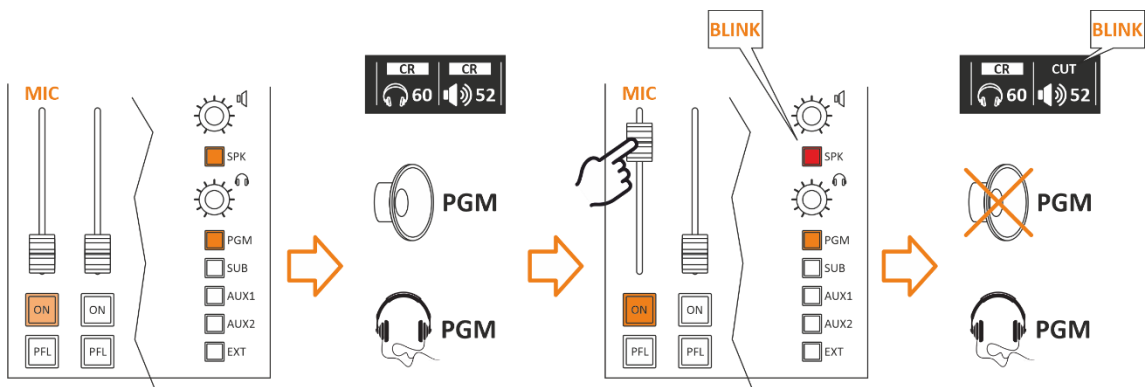

When you open the associated source with a **CUT** function you will see it will **MUTE** CR Loudspeakers output to prevent LOOP audio and the SPEAKER icon at LCD will start blinking.

ATT. (attenuation) MODE: It helps reduce acoustic flux from flowing into the speakers. It possible to decrease the speakers output -40, -30, -20 or -10 dB.

EX.: If we want to reduce the sound coming out of the speakers by **40 dB** less than the current value, then we have to choose **-40**. The same thing if we want to reduce the current volume when opening any of the microphones with a value of **10** decibels, then we have to choose **-10** and confirm the selection by pressing the button around until the selection color changes to yellow.

The **CUT** mode is triggered by the change from **OFF** to **ON** of a microphone source to which it has been set closing of the loudspeaker.

As shown in the MENU this function (**CUT**) is associated only with the loudspeakers, to avoid LARSEN effects “feedback loop” from occurring between the nearby loudspeakers and On-Air microphones.

On the other hand, if you need to **MUTE** the loudspeakers manually just **PRESS** the volume knob down. **PRESS** the volume knob a second time or rotate it to activate the loudspeakers output and amplification or attenuation. The status of **MUTE-SPK** is indicated by a red cross on the SPEAKER icon.

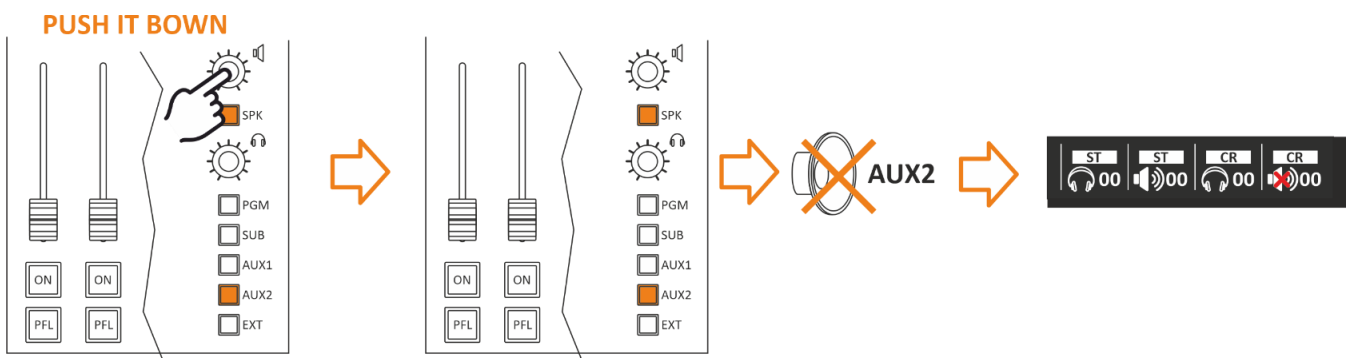

TALKBACK



MENU / AUDIO / OUTPUTS / MONITOR / SPEAKER / SPK-CRM / TALK BACK (OFF, ON)

Here where can **disable/enable** the **TALKBACK** communications in speaker’s output. Normally the talkback is used to communicate between the mixer man and the people in the studio via headphones. This option gives you the possibility to hear the people talking in TALKBACK the studio via the **CR** (Control Room loudspeakers).

B. CONTROL ROOM HEADPHONE (HDP-CRM)

- This section is used for the management of the HDP .
- The rotary control knobs allow you to **amplify/attenuate** the audio level.
- The headphone audio level goes from **0** to **99** is the maximum allowed level. Can set the maximum level by going to this page:

MENU / AUDIO / OUTPUTS / MONITOR / SPEAKER / SPK-CRM

- The step of the headphone adjustment is **1 dB** and the level goes from **-80 dB** to the maximum of **+19 dB**.
- By **pressing the knob**, you can mute  or play the **ST-STUDIO** speakers if it is already muted.
- To unmute the headphone  just press their knob or **increase/decrease** the audio level by rotating the knob and confirm that by clicking on the same knob.
- The Speaker's level is displayed in the bottom-right section of the LCD.

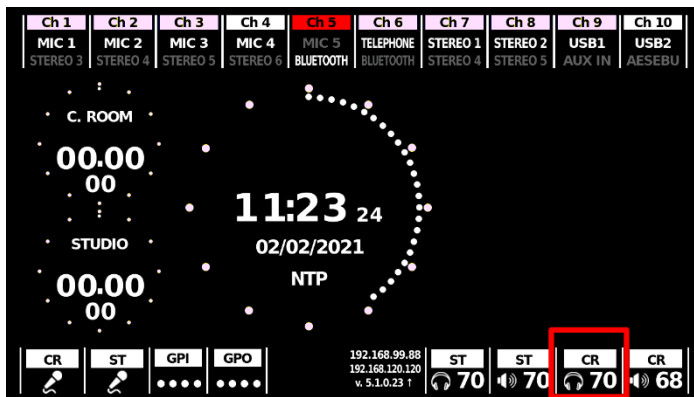
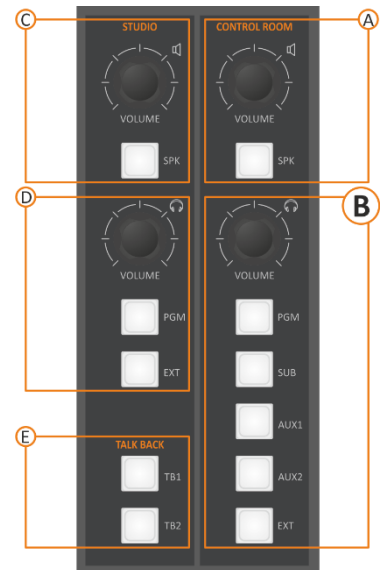

The status of **MUTE-HDP** is indicated by a red cross on the HEADPHONE icon.

PUSH IT BOWN

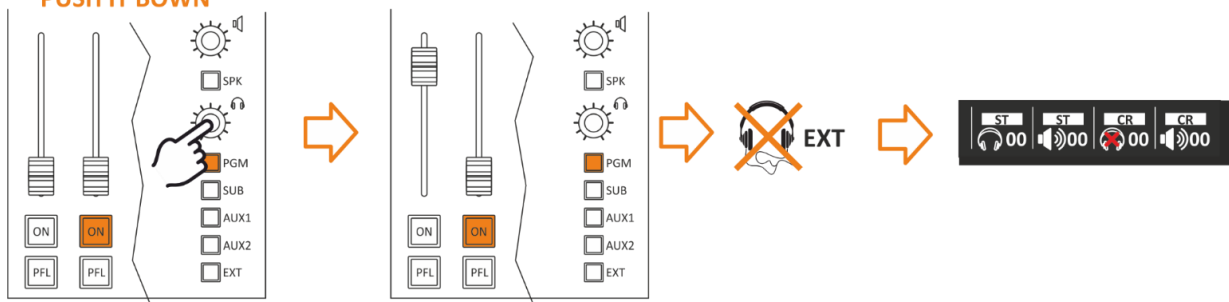

MODE: SEL+PFL or SEL

MENU / AUDIO / OUTPUTS / MONITOR / SPEAKER / SPK-CRM / MODE



PFL (pre-fader listening): This mode allows you to listen in speakers to the audio of the single-channel **before** the intervention of the fader.

SEL (one selection): This option allows you to listen in headphones  to only ONE selected output from the output section (PGM, SUB, AUX1, AUX2, EXT).

SEL+PFL: This mode allows you to listen to **ONE selected output** or **PFL** if press the button  PFL of one channel.



C. STUDIO – SPEAKERS

- This section is used for the management of the **ST Studio Speakers**.
- The rotary control knobs allow you to **amplify/attenuate** the audio level.
- The loudspeakers audio level goes from **0** to **99** is the maximum allowed level. Can set the maximum level by going to this page: **MENU / AUDIO / OUTPUTS / MONITOR / SPEAKER / SPK-CRM**
- The step of the loudspeaker adjustment is **1 dB** and the level goes from **-80 dB** to the maximum of **+19 dB**.
- By **pressing the knob**, you can mute  or play the **ST-STUDIO** speakers if it is already muted.
- To unmute the speaker  just press their knob or **increase/decrease** the audio level by rotating the knob and confirm that by clicking on the same knob.
- The Speaker's level is displayed in the bottom-right section of the LCD.

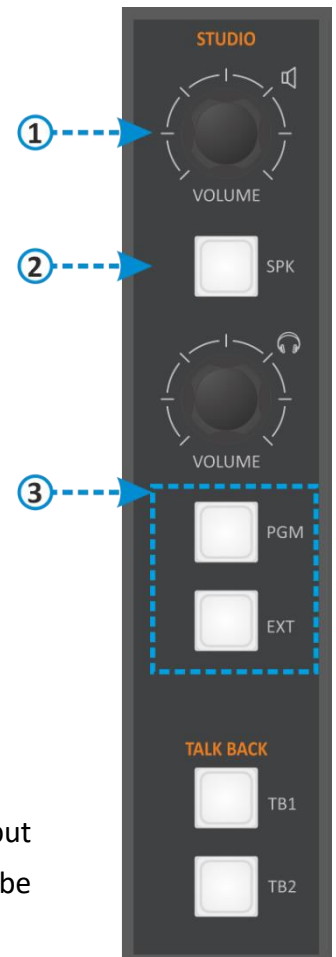
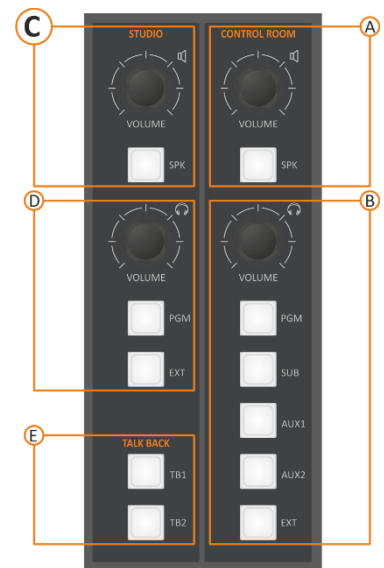
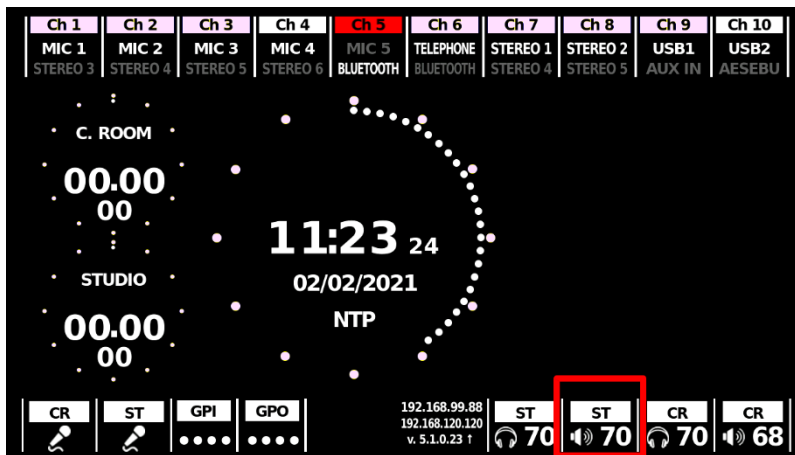

MODE: 2SEL+PFL, 2SEL, SEL+PFL, SEL, PGM, SUB, AUX1, AUX2 or EXT

MENU / AUDIO / OUTPUTS / MONITOR / SPEAKER / SPK-STUDIO / MODE

PFL (pre-fader listening): This mode allows you to listen in speakers  to the audio of the single-channel **before** the intervention of the fader.

SEL (one selection): This option allows you to listen in speakers to only ONE selected output from output section 3 (PGM, EXT).

SEL+PFL: This mode allows you to listen to **ONE selected output** or PFL if press the button  PFL of one channel.

2SEL (two selection): This option allows you to listen to ONE selected output section 3 (PGM, EXT), And by pressing the **SPK** in section ② button you will be able to switch between two different output in the speakers.

CUT-ATT-MODE

MENU / AUDIO / OUTPUTS / MONITOR / SPEAKER / SPK-STUDIO / CUT-ATT-MODE

CUT MODE: it's allowed the microphone to **CUT OFF** the audio of control room loudspeakers once the microphone goes to ON.

The opening of a microphone channel (if configured appropriately) can generate the closing command of the loudspeakers.

That is possible to choose one or more microphone to cut the loudspeaker output of the **ST** "studio" by following this path:

MENU / AUDIO / INPUTS / MIC / SPK-CUT (OFF, ST, CR, CR+ST)

When you select **ST** or **ST+CR**, press down the knob to confirm the selection and it will show up in yellow color.

When you open the associated source with a **CUT** function you will see it's will **MUTE ST** Loudspeakers output to prevent LOOP audio and the **SPEAKER** icon at LCD will start blinking in red color.

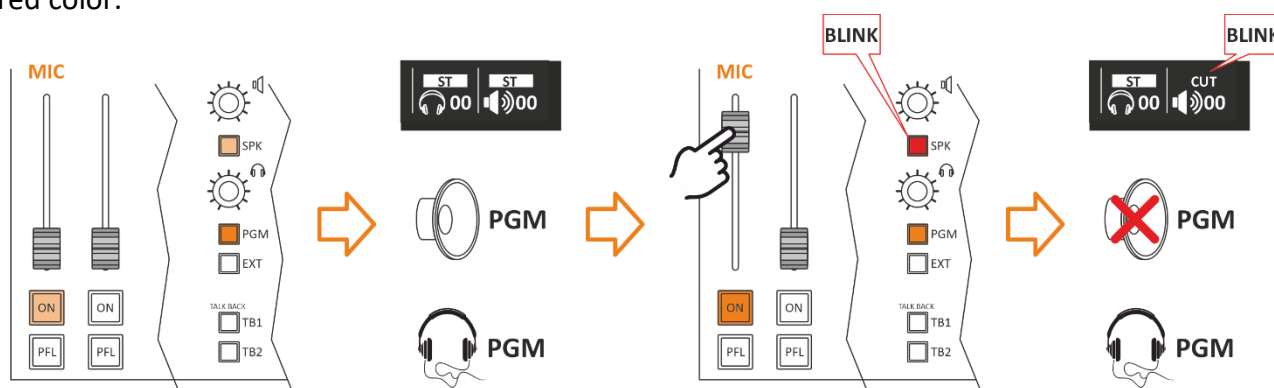

ATT. (attenuation) MODE: It helps reduce acoustic flux from flowing into the speakers. It possible to decrease the speakers output **-40, -30, -20** or **-10 dB**.

EX.: If we want to reduce the sound coming out of the speakers by **40 dB** less than the current value, then we have to choose **-40**. The same thing if we want to reduce the current volume when opening any of the microphones with a value of **10** decibels, then we have to choose **-10** and confirm the selection by pressing the button around until the selection color changes to yellow.

The **CUT** mode is triggered by the change from **OFF** to **ON** of a microphone source to which it has been set closing of the loudspeaker.

As shown in the MENU this function (**CUT**) is associated only with the loudspeakers, to avoid LARSEN effects "feedback loop" from occurring between the nearby loudspeakers and On-Air microphones.

The **CUT** mode is triggered by the change from **OFF** to **ON** of a microphone source to which it has been set closing of the Studio loudspeaker, using the following to set this function:

As shown in the MENU this function (**CUT**) is associated only with the loudspeakers, to avoid LARSEN effects "feedback loop" from occurring between the nearby **ST** loudspeakers and On-Air microphones.

If you need to **MUTE** the loudspeakers just **PUSH** the volume knob.

PUSH the volume knob a second time or rotate it to activate Studio loudspeakers output and amplification or attenuation.

The status of **MUTE-SPK** is indicated by a red cross on the **SPEAKER** icon on the LCD display.

D. STUDIO – HEADPHONES SOURCES & LEVEL

- This section is used for the management of the **HDP-STUDIO** headphones 🎧.
- The rotary control knobs allow you to **amplify/attenuate** the audio level.
- The headphone audio level goes from **0** to **99** is the maximum allowed level. Can set the maximum level by going to this page: **MENU / AUDIO / OUTPUTS / MONITOR / HEADPHONES / HDP-STUDIO**
- The step of the headphone adjustment is **1 dB** and the level goes from **-80 dB** to the maximum of **+19 dB**.
- By **pressing the knob**, you can mute 🚫 or play the **HDP-STUDIO** headphone if it is already muted.
- To unmute the headphone 🎧 just press their knob or **increase/decrease** the audio level by rotating the knob and confirm that by clicking on the same knob.
- The headphone level is displayed in the bottom-right section of the LCD.

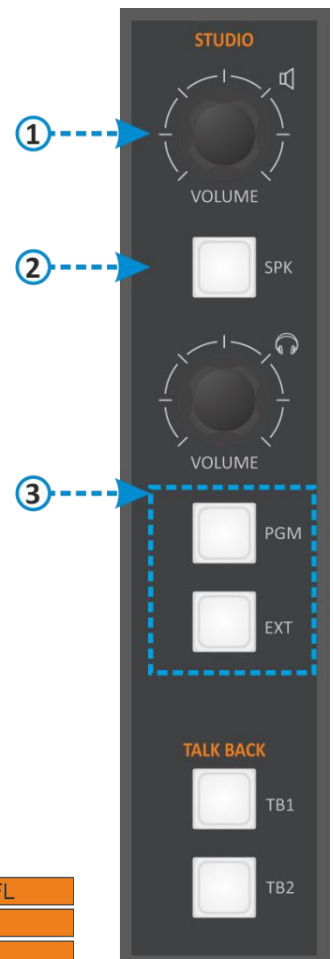
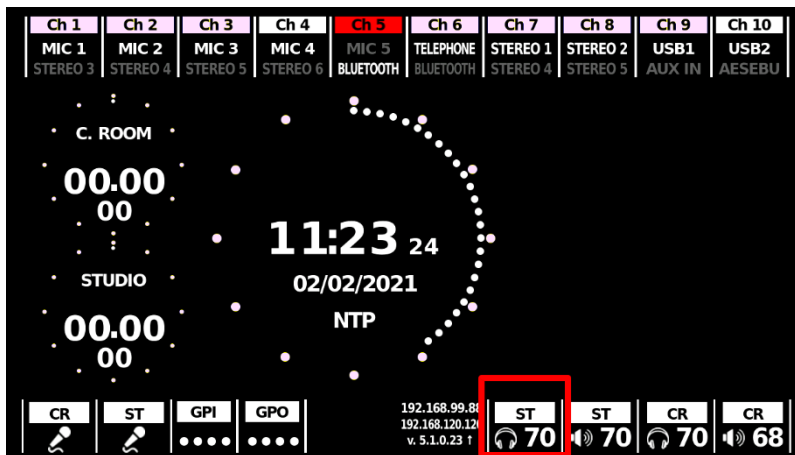
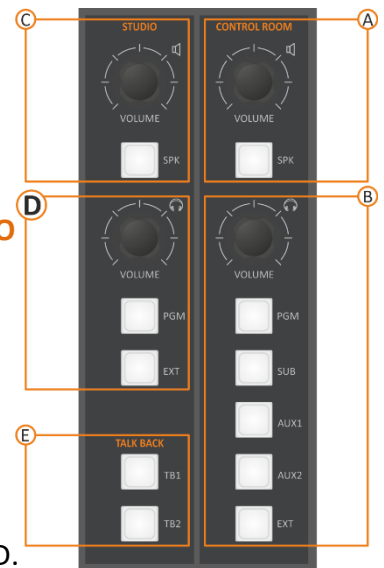

MODE: SEL+PFL, SEL, PGM, SUB, AUX1, AUX2 or EXT

MENU / AUDIO / OUTPUTS / MONITOR / SPEAKER / SPK-STUDIO / MODE

PFL (pre-fader listening): This mode allows you to listen in headphones 🎧 to the audio of the single-channel **before** the intervention of the fader.

SEL (one selection): This option allows you to listen in headphones to only ONE selected output from output section **3 (PGM, EXT)**.

SEL+PFL: This mode allows you to listen to **ONE selected output** or **PFL** if press the button PFL of one channel.

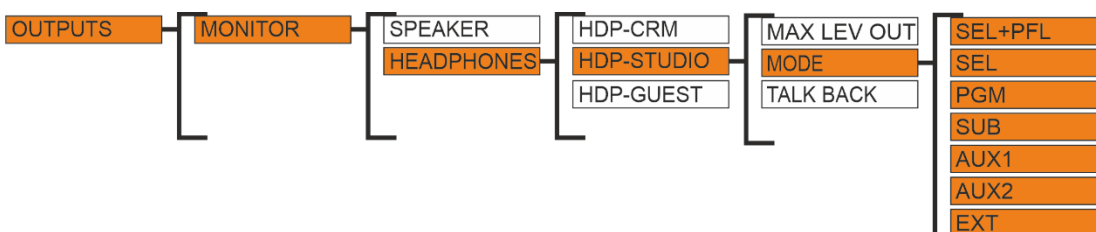

E. TALKBACK – FROM CONTROL ROOM TO THE STUDIO

This section is used for the management of the TB “TALKBACK” from the CONTROL ROOM to the Studio. By pressing **TB1** it’s possible to speak with the anchorman in the STUDIO from the CONTROL ROOM.

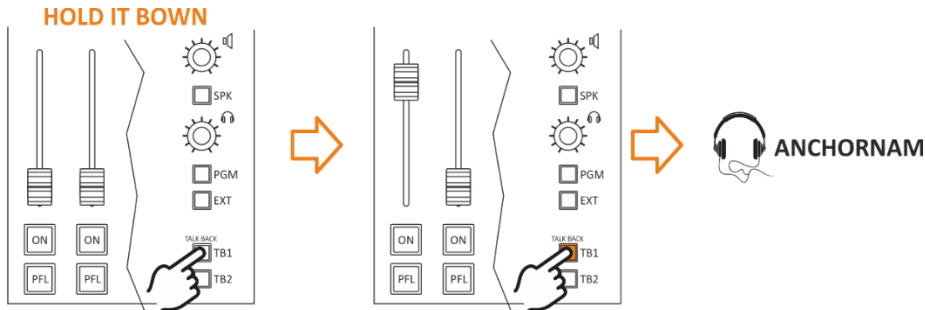

By pressing **TB2** it’s possible to speak with the GUESTS in STUDIO.

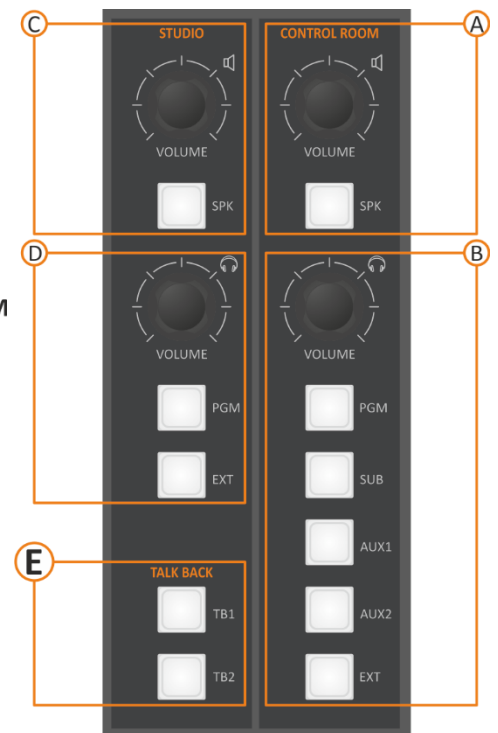
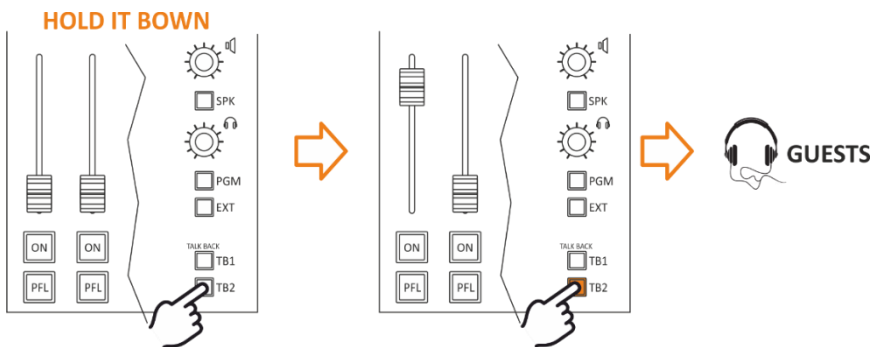

2.6 SMART KEY / JINGLE BUTTONS*

Smart Keys are buttons to which internal/external functions can be associated with the mixer, for example, they could be used as:

- Recall of 8 mixer configurations - For example, re-configuration of source assignments.
- Keys of the Jingle Machine of the - DjPro.
- Send commands to a remote GPO - for example, a Moxa.
- Send UDP commands to an external system.

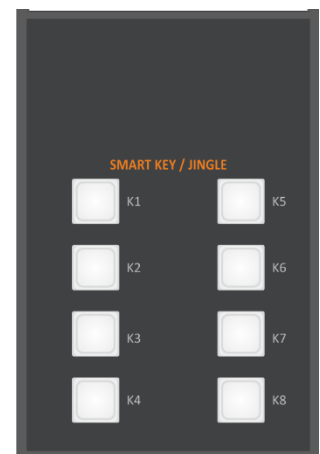

* see the [REMOTER PART](#) for more information.

2.7 DISPLAY 7" TFT AND CONTROL BUTTONS

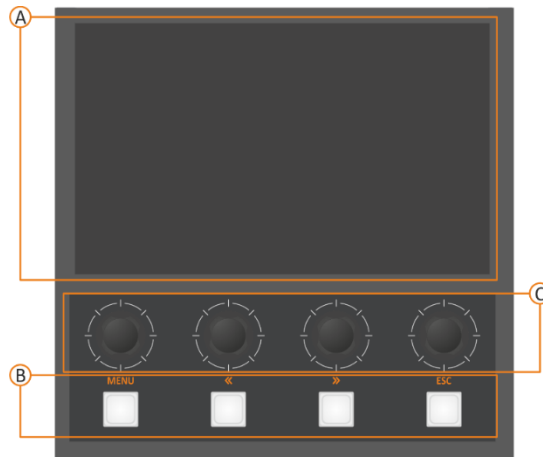

A. COLOR DISPLAY 7" - 800X480 RESOLUTION

The display is used to control the mixer setting and monitor all the parameters and it has its own configuration menu. The display has some parameters that can be changed it like **DIMMER** and **LOGO**. It is possible to adjust the display brightness, allowing you to deal with any environmental situation. You can find the parameter in the following menu: **GENERAL SETTINGS/LIGHT & DISPLAY/DISPLAY/DIMMER (low, mid, high)**. It is possible to have the logo of your own station on the Mixer display. The image must be **330x280px** in **PNG** format.

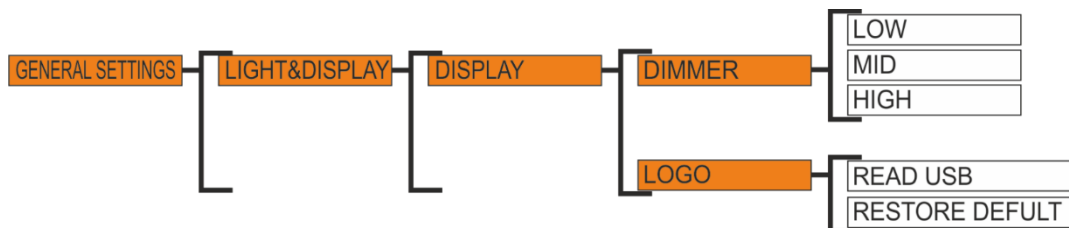

The HOME THEME parameter defines what to see on the display in standard conditions when no function has been recalled.

The following picture is the HOME PAGE:

1. ON/OFF channel STATUS.
2. Source names associated with channels.
3. Logo display.
4. NTP synchronized clock & Mic timer.
5. ONAIR mic status.
6. GPIO 1&2 status.
7. Speakers and Headphones status.
8. Firmware release and IP address.

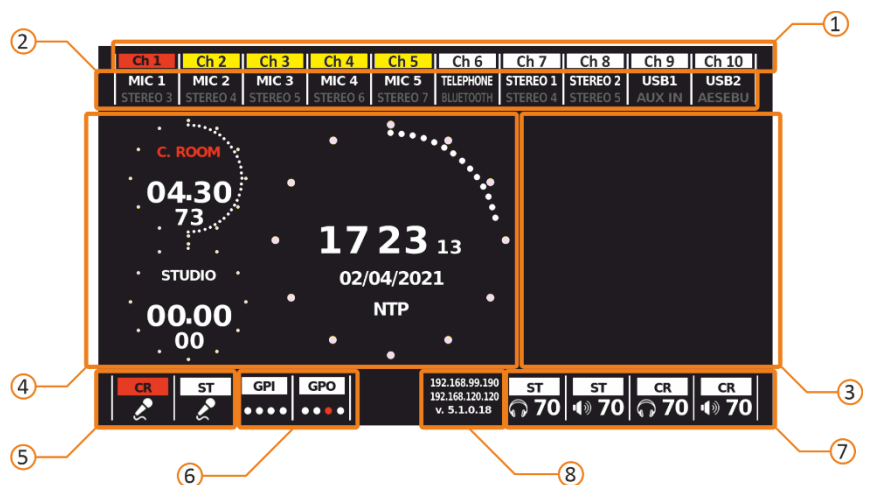

B. BUTTONS FOR THE MENU NAVIGATION

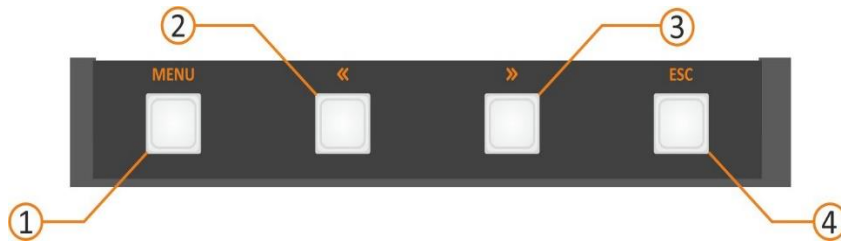

1) The **MENU** button switches from HOME to MENU. With this button, you can recall the mixer configuration menu.

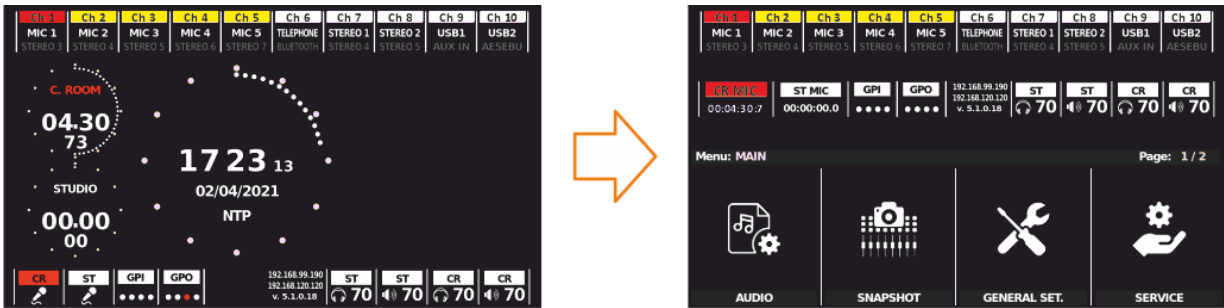

>> and << **(2) (3)** Buttons allow you to move between pages of **parameters/functions** on the same menu level. **ESC (4)** allows you to exit from the menu level going up in the menu.

C. ENCODER FOR THE MENU NAVIGATION

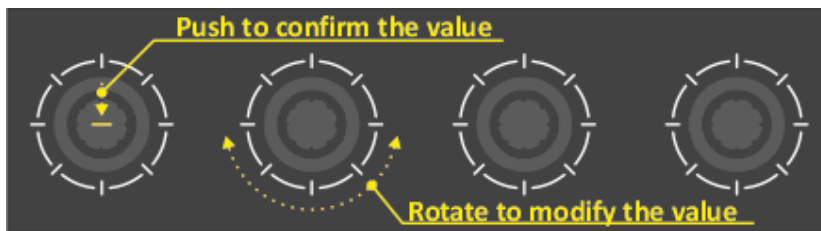

- The 4 knobs allow you to adjust and confirm the menu parameters.
- It is also possible to **PUSH** the knob to confirm the parameter setting.
- Menus are designed to have a perfect matching between graphics and knobs.
- Parameter changes will be directly applied to the audio of the aired channel.
- The yellow value represents the stored value.
- While a knob is being moved the circle becomes white. A white value appears in the middle of the circle. The new value represents an instantaneous value that is different from the stored one.
- Push the related knob to confirm the parameter changes. Once you have confirmed the new value, the graphic will become yellow again.
- At the **ESC** pressing or at the next screen change if the changes will not be confirmed, the value will be restored to the one previously saved.

D. MENU display parts

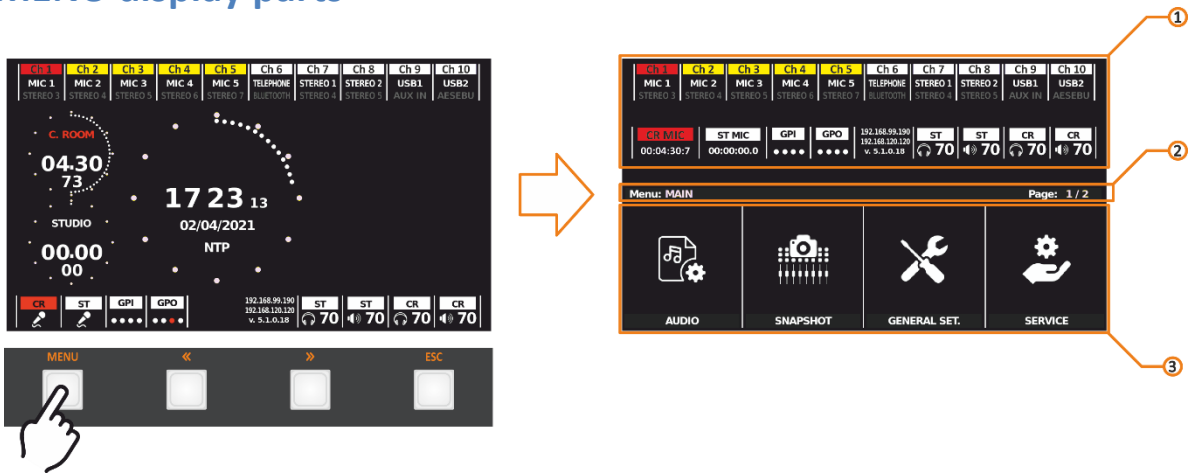

1. In this part of the display can see some useful elements and information depending on the location from the MENU.
2. From here you can browse all lists available in the menu.
3. To navigate the root of your page. The page number indicates the pages available and the current page.

3. MENU

3.1 AUDIO/INPUTS

You can set Input source parameters from the menu **MENU / AUDIO / INPUTS** by PUSH/RUTATE the knobs as in the following steps.

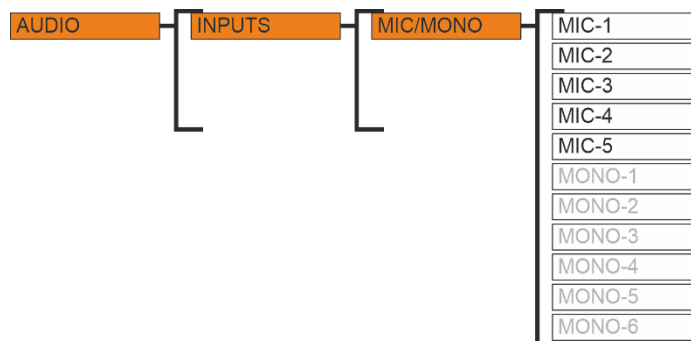
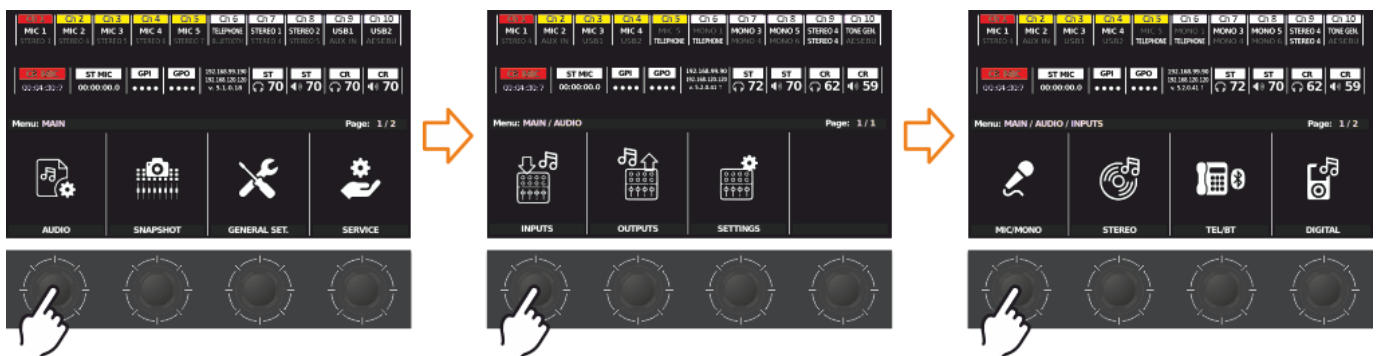

From this level of the menu, you choose which input source that you like to customize.

3.1.1 MIC (MIC-1 to MIC-5)

Here we can find all Microphones source parameters (**MIC-1 to MIC-5**) That can manage the five microphones' inputs like changing the **NAME, GAIN, PAL/PAN, PREAMP, PHASE, PHANTOM 48V**, and many other functions we going to explain it briefly in below.

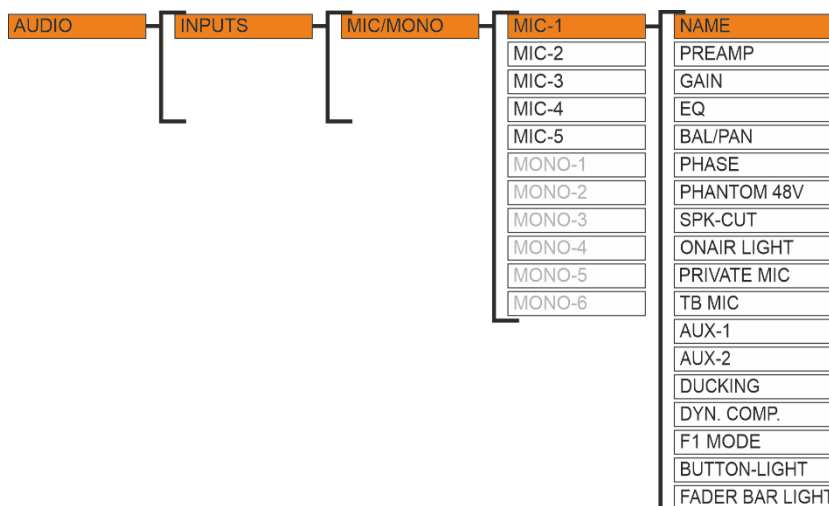
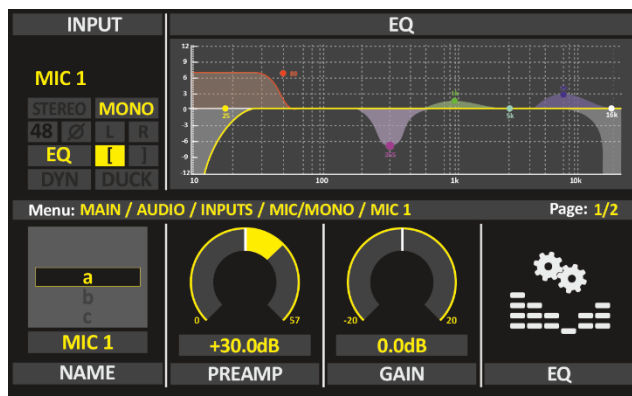

3.1.1.1 NAME:

This parameter allows the assignment of a **LABEL** to the various input sources. It is not possible to have a **LABEL** of more than 8 characters. To change the microphone name and sign it as you like, it's so easy way just rotate and push the knobs. To end editing the **LABEL**, just push the ESC button. just follow the next steps. The description works the same for all Inputs. (In the example we are going to set the channel name as (MIC1).

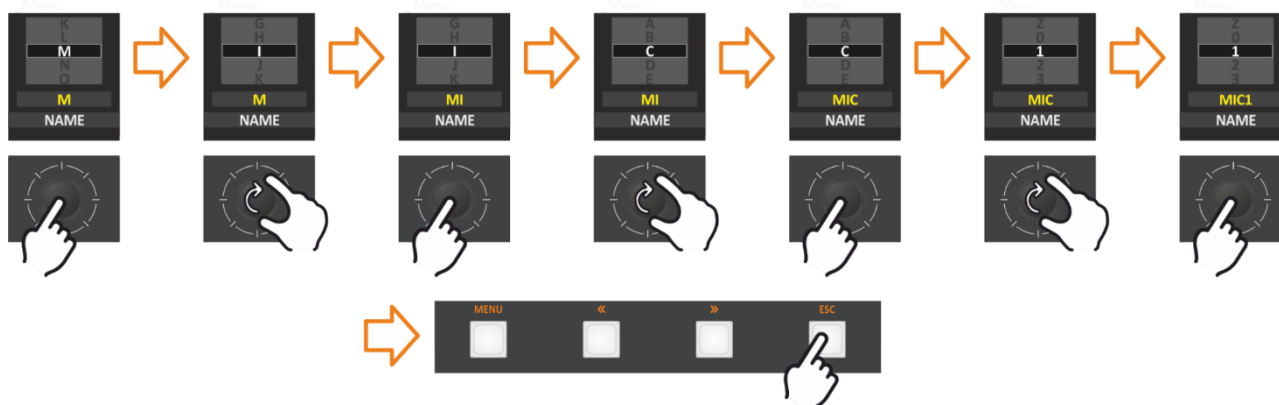

3.1.1.1 PREAMP:

The preamplifier is typically used to amplify signals from analog sensors such as microphones. It allows you to convert a weak signal for sending to a power amplifier or loudspeakers without any noise or distortion.

This parameter changes the Input **PREAMPLIFIER**.

The parameter has a **0.5 dB** step for a maximum of **57.0 dB**.

N.B.: When you adjust the **PREAMP** parameter, you have a real-time change of the parameter value and the real-time perception of the **PREAMP** change. The Graphics will become white to indicate the parameter change, and it will become yellow again after the confirmation.



3.1.1.2 GAIN:

This parameter allows you to adjust the input **GAIN** to bring the source to the right level. The input Gain has steps of **0.1 dB**.

N.B.: When the parameter control is activated, in real-time the parameter value is updated, perceiving the increase and decrease of the **GAIN**, the graphics will change from yellow to white until the parameter is confirmed.

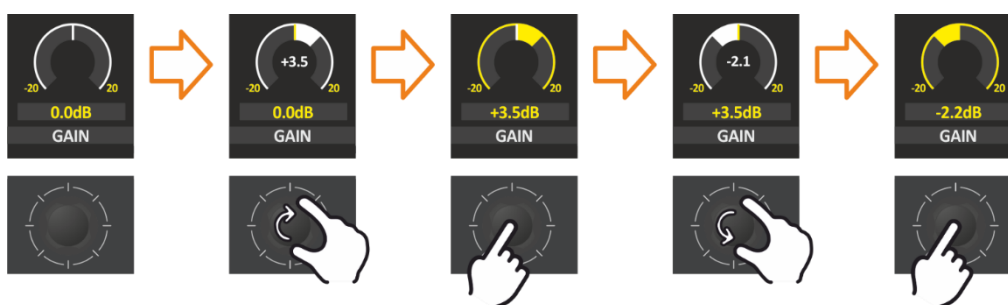
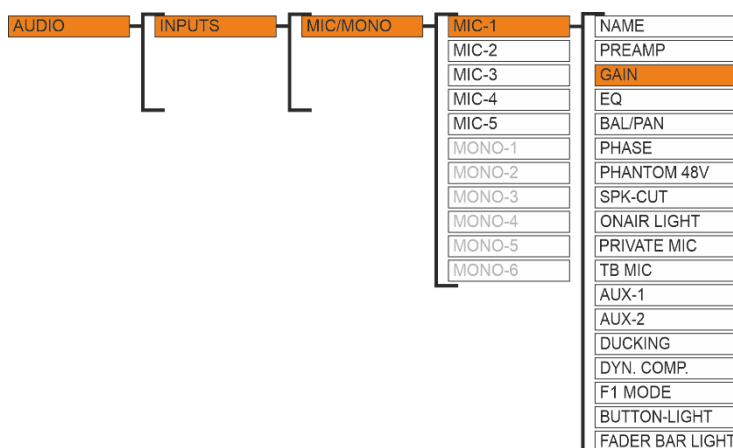

3.1.1.3 EQ:

These are graphic equalizers that provide an adjustable band between **22.4 Hz** and **20 kHz**. A master volume slider compensates for changes in volume caused by the equalization. An equalizer allows the sound in specified frequency bands to be amplified or reduced, to adjust the quality and character of the sound. A maximum boost or cut is available for **LOW CUT** and **HI-CUT**.

Press the Equalizer knob to engage in this section. Select one of the 7 frequency bands with the **LOW CUT, BASS, BASS-MID, MID, MID-HIGH, HIGH, and HI-CUT**.

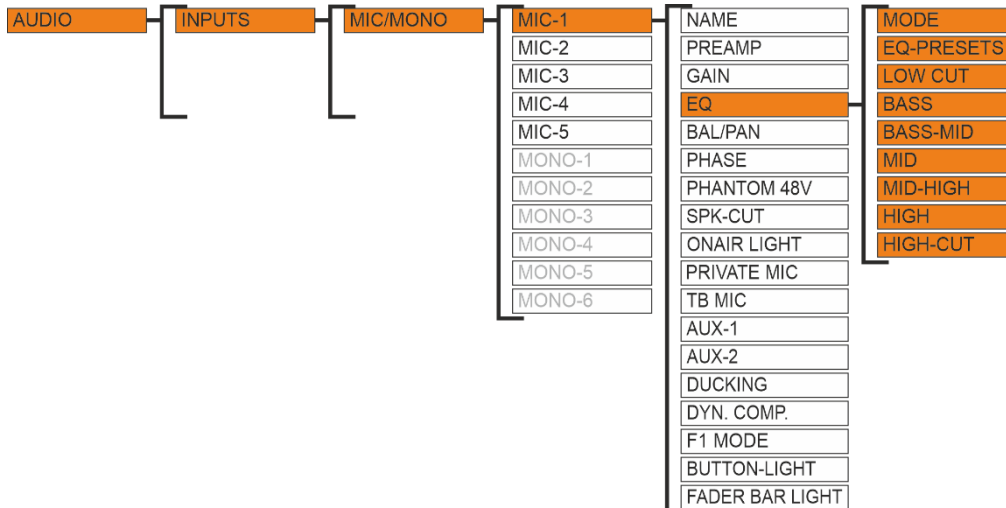

Press the next button (**◀**) or (**▶**) to switch between the pages of **EQ** types that are available.

Select the specific frequency to be adjusted with the **FREQUENCY** knob, and adjust the bandwidth of the **EQ** with the knob, also you can choose between **PEAK** or **SHELVING** of BASS and HIGH. Finally, boost or cut the selected frequency with the **Gain** knob.

After confirming any editing, you will see clearly the change that you do at the graphic equalizer display with different color signals, as well as it is effective at the input source quality and character.

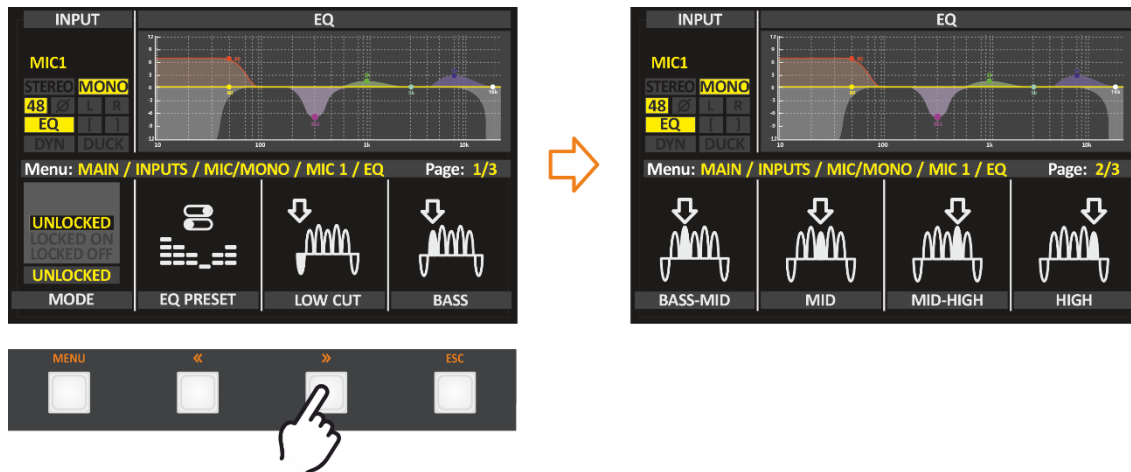

MODE: This function has been added to prevent unauthorized people from activating or deactivate the equalizer.

UNLOCKED: that is mean the equalizer is free and can activate or deactivate the equalizer from the EQ button on the surface.

LOCKED ON: that is mean the equalizer of this channel will be still ON and cannot turn off from the EQ button.

LOCKED OFF: that is mean the equalizer of this channel will be still OFF and cannot turn ON from the EQ button.

EQ PRESET: This function is useful to save and recall the equalizer settings. These settings are saved at the internal memory and it is not exportable.

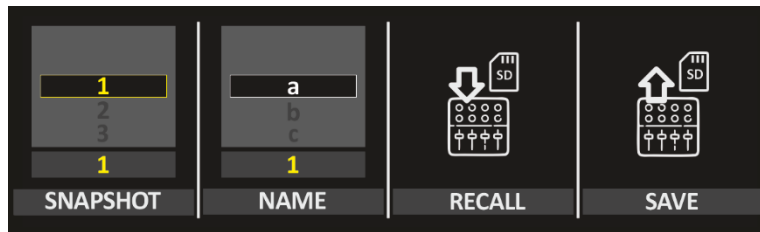

SNAPSHOT: it's able to save ten different EQ PRESET by select the position of the new save from 1 to 10 before save it.

NAME: here is can change the name of the PRESET to identifying them.

RECALL: to recall one of the PRESETs that already saved in internal memory.

SAVE: to save the actual equalizer setting as a PRESET.

LOWCUT: This is an audio frequency filter that cuts out all of the low sounds below a certain frequency. On console you are given knobs to control the frequency of the low cut in a full range from **22.4Hz** to **20.0KHz**. Also, you can control how gradual or steep the cut is. Doing so will eliminate the amplification of unwanted low sound. unwanted sound can be:

- Microphone handling or floor rumble (from bumping the mic or stepping on the floor that the mic stand is sitting on).
- The popping of “P’s” and “B’s” from a voice.
- Unwanted electrical hum (60hz).

When you active the **LOWCUT** function and confirmed it, that change will appear immediately at the output sources, and it will be shown in **the EQ** graphic display as well the **LOWCUT** mark ([]) will change to yellow color.

HIGH CUT: Is an audio frequency filter that cuts out all of the frequency above which the source signals a certain frequency. manipulates the reflection density in the simulated room.

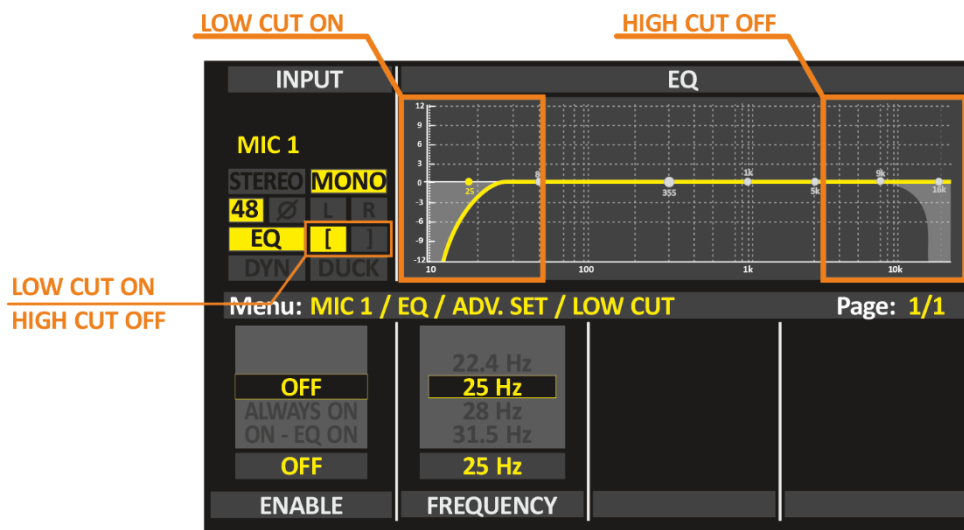

BASS, BASS-MID, MIDDLE, MID-HIGH, HIGH:

In the Parametric equalizers allow the adjustment of multi-band frequency equalizers which allow you to control the three primary parameters: AMPLITUDE, CENTER FREQUENCY, and BANDWIDTH.

The amplitude of each band can be controlled by the **GAIN** knob.

The center frequency can be shifted by the **FREQUENCY** knob.

Bandwidth (which is inversely related to "Q") can be widened or narrowed by the **Q** knob.

equalizers are capable of making much more precise adjustments to sound than other equalizers.

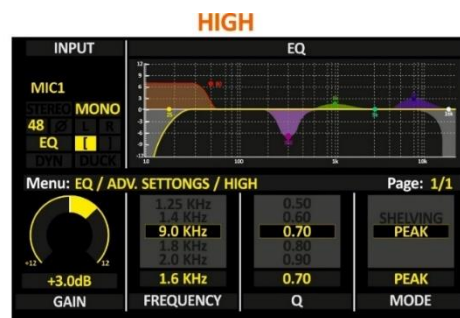
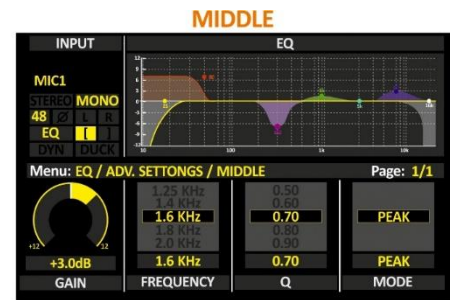
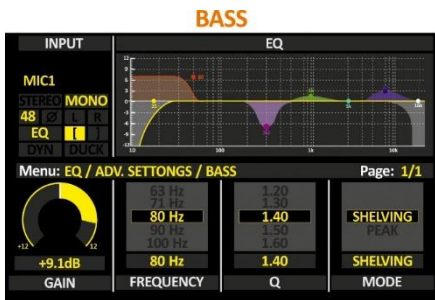
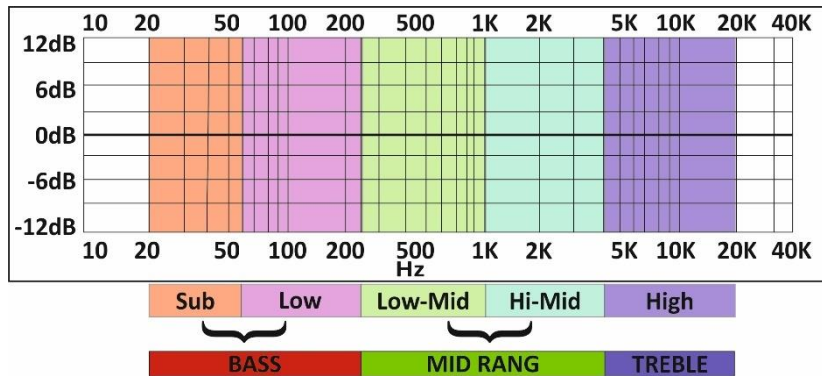

3.1.1.4 BAL/PAN:

This parameter changes the Input **BAL/PAN**.

The parameter has a **1.0 dB** step.

N.B.: When you adjust the **BAL/PAN** parameter, you have a real-time change of the parameter value and the real-time perception of the **BAL/PAN** change. The Graphics will become white to indicate the parameter change, and it will become yellow again after the confirmation.

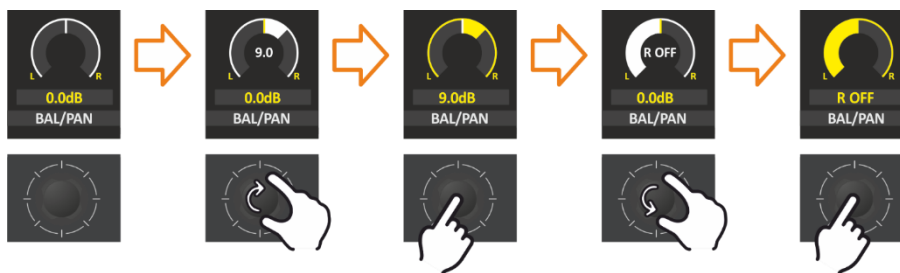
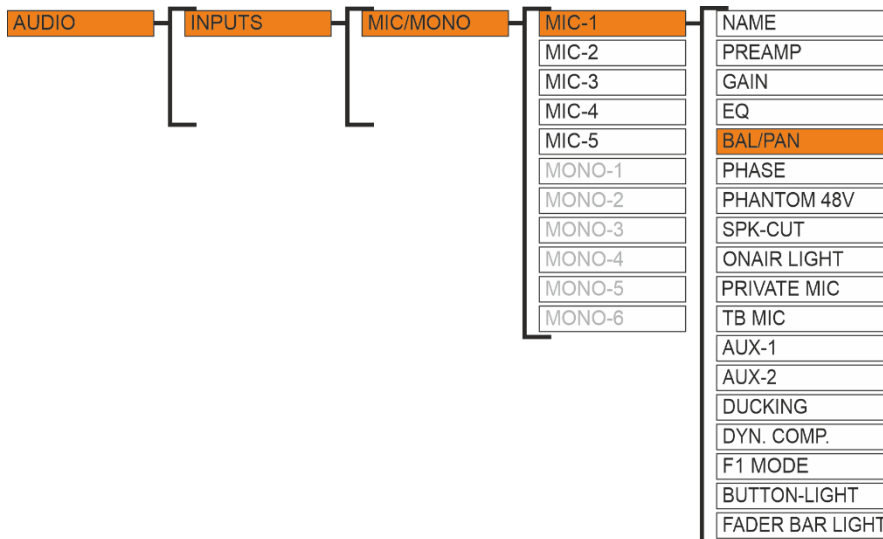

3.1.1.5 PHASE:

This option was created to control the phase of the microphone by flipping the phase to prevent **PHASE CANCELLATION**.

By rotating the knob of **PHASE**, you can flip it **180°**.

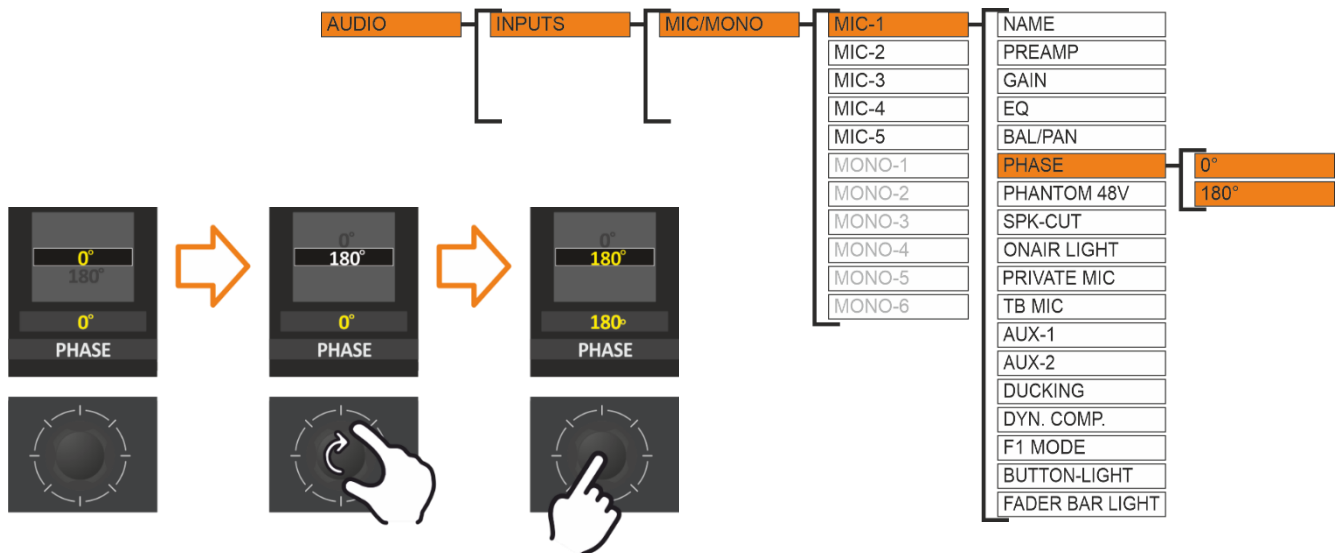

3.1.1.6 PHANTOM 48V:

This option allows you to turn the phantom power 48V **ON/OFF** for use with microphones (if the microphone requires it, such as a condenser microphone). The Phantom is shown in the **channel Set Panel**.

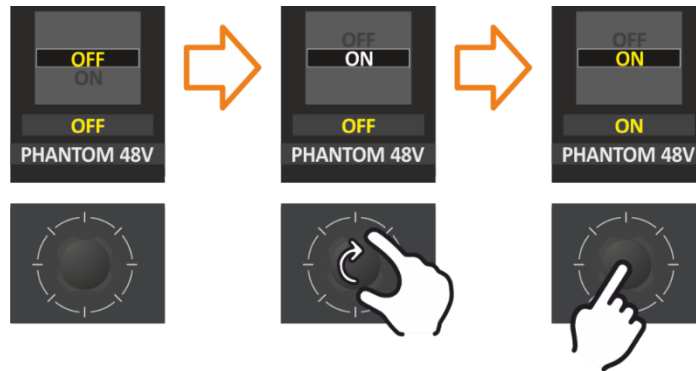
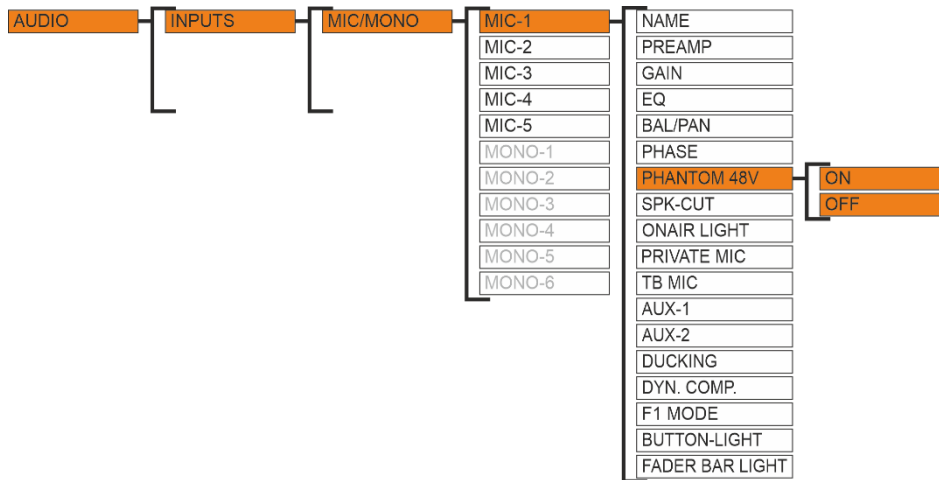

3.1.1.7 SPK-CUT:

From this function, you can assign the **MIC** to the cut source that has to put the SPEAKERS in mute (**Control Room** or **STUDIO**). it is possible to select one source (**CR, ST**) or both of them together.

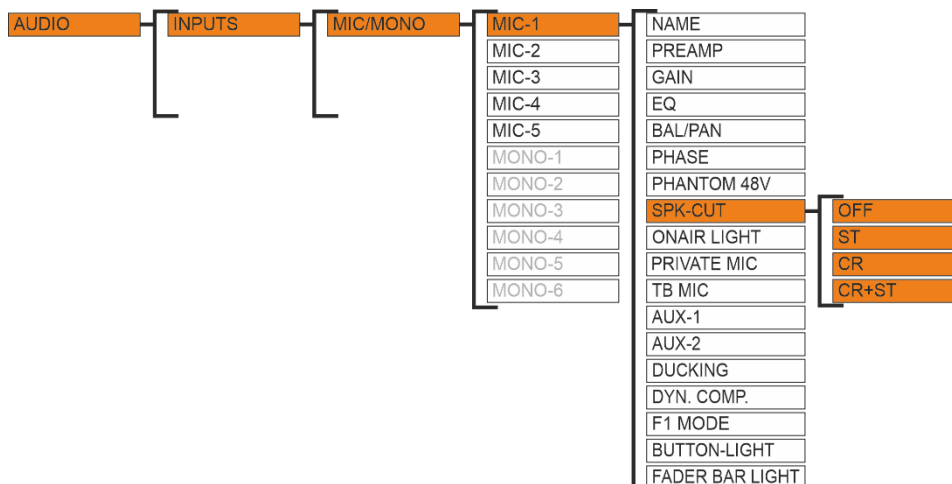

The opening of a microphone source (if configured appropriately) can generate the closing command of the loudspeakers.

That is possible to choose one or more source to cut the loudspeaker.

When you open the associated source with an **SPK-CUT** function, you will see it's will **MUTE CR** (Control Room) Loudspeakers output and the SPEAKER icon at LCD will start blinking.

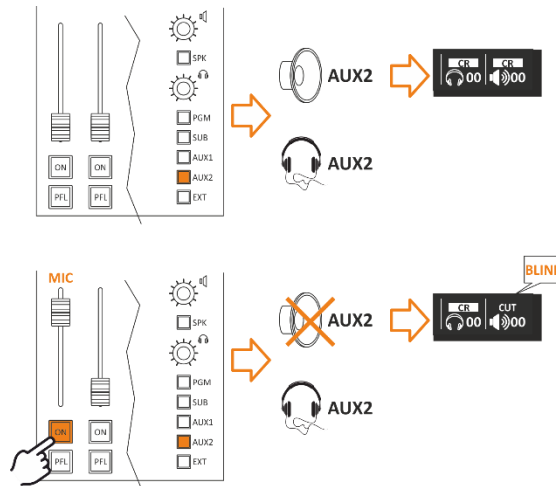

As shown in the MENU this function (**SPK-CUT**) is associated only with the loudspeakers, to avoid **LARSEN** effects “feedback loop” from occurring between the nearby loudspeakers and On-Air microphones.

3.1.1.8 ONAIR LIGHT:

From here can control the **ON AIR** light through **GPO** command. If you select **CR** (Control Room ON AIR LIGHT), once this source fader is open, it will activate the **GPO** assigned as **CR-ON AIR**.

To verify if one of 4 GPO is assigned as **CR-ON AIR** can follow this path: -

MENU / MAIN / GENERAL SET. / GPIO / GPO

3.1.1.9 PRIVATE MIC:

The private mic is the microphone that can talk to the caller privately and this conversation is not audible in the loudspeakers and MAIN outputs.

3.1.1.10 TB MIC:

OFF: the microphone is not a Talkback mic. This selection can disable the microphone to disconnect it from the talkback connection.

ON-CR: to talk with the Control Room via this microphone.

ON-ST: to talk with the Studio using this microphone.

3.1.1.11 AUX1, AUX2:

From this section, you have the possibility to set **AUX-1** and **AUX-2** to be (**POST FADER**, **PRE-Fader**, or **PRE FADER ALWAYS ON**) this choice is of every single channel.

When you set **AUX-1** and **AUX-2** to be **PRE FADER**. The **FADER** does not affect the **AUX** output signal in this case.

When you set **AUX-1** and **AUX-2** to be **PRE FADER ALWAYS ON**. The **FADER** and **ON/START** buttons do not affect the **AUX** output signal in this case.

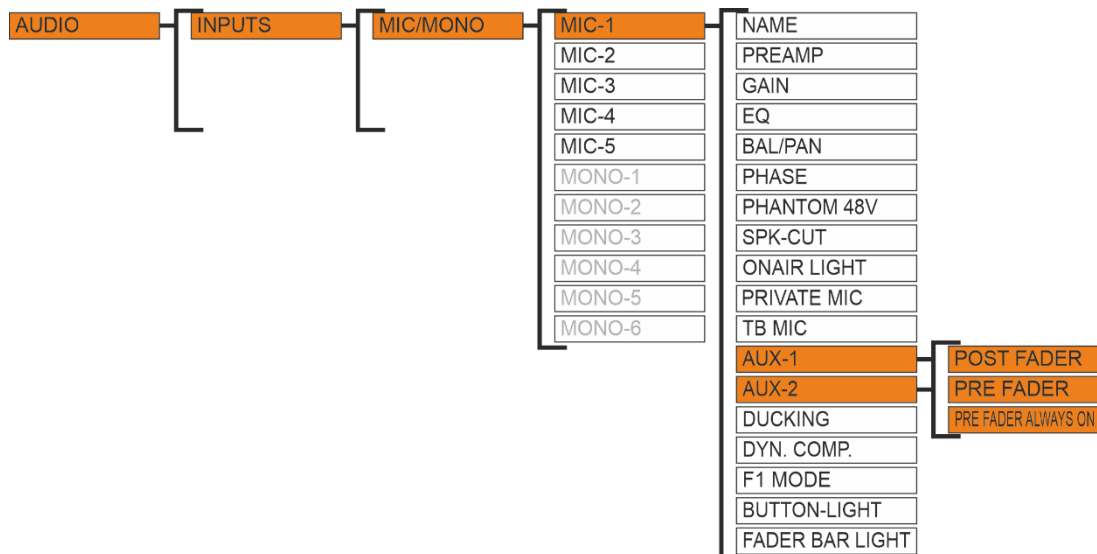

3.1.1.12 DUCKING:

In the musical programs when it is mixed with a speech that needs drop music when the anchorman or the guest starts speaking. the background music instantly drops, then it pops right back up again as soon as that person finishes talking. This happens when the ducking effect in action.

Ducking temporarily lowers, or “ducks,” the volume level of a specified audio signal anytime a second specified audio signal is present. In live sound, ducking is commonly used to lower background music anytime a person speaks, then raises it when that person finishes speaking

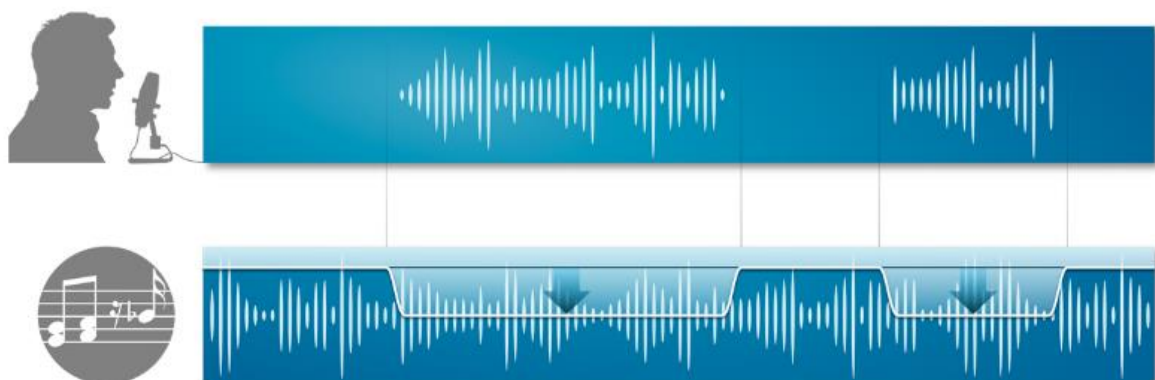

3.1.1.13 DYN. COMP.:

Dynamic range compression (**DRC**) or simply compression is an audio signal processing operation that reduces the volume of loud sounds or amplifies quiet sounds thus reducing or compressing audio signals in **DYNAMIC RANGE**. Compression is commonly used in sound recording and reproduction, broadcasting, live sound reinforcement, and some instrument amplifiers.

THRESHOLD

A compressor reduces the level of an audio signal if its amplitude exceeds a certain threshold. The threshold is commonly set in decibels (**dB**), where a lower threshold **-70 dB** means a larger portion of the signal is treated. When the signal level is below the threshold, no processing is performed and the input signal is passed, unmodified to the output. Thus, a higher threshold of **0 dB**, results in less processing, less compression.

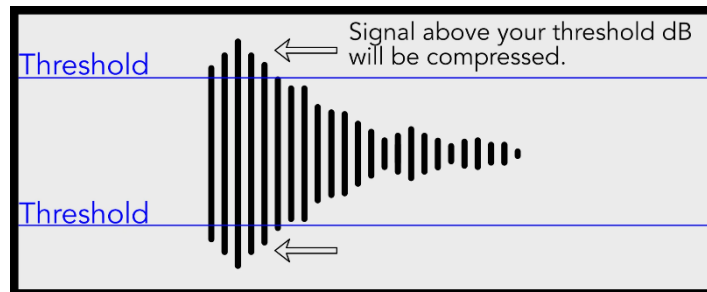

RATIO

When the signal becomes louder than the threshold, the compressor reduces the gain based on the ratio setting. Without getting too mathematical, the **ratio** of a compressor determines how much gain reduction is applied to a signal after it crosses the threshold.

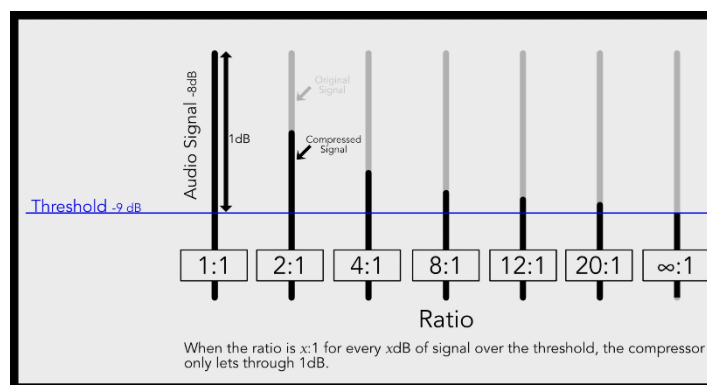

With a ratio of **2:1**, for every **2 dB** above the threshold, the compressor only allows **1 dB** above the threshold through. With a ratio of **4:1**, for every **4 dB** above the threshold, the compressor only allows **1 dB** above the threshold through. With a ratio of **10:1**, for every **10 dB** above the threshold, the compressor only allows **1 dB** above the threshold through.

3.1.1.14 F1 MODE:

This feature gives the ability to change the action of the **F1** button.

NONE: no action.

TB: By pressing **F1** can talk privately with the studio in Talkback (**TB**).

DUCKING: to activate or deactivate the DUCKING on this source.

3.1.1.15 BUTTON-LIGHT, FADER BAR LIGHT:

Button light LED it's to indicate the channel status.

Fader bare LED indicates the fader level.

From this section, it is easy to change LED's color and mark it as you want by rotate and push the knobs.

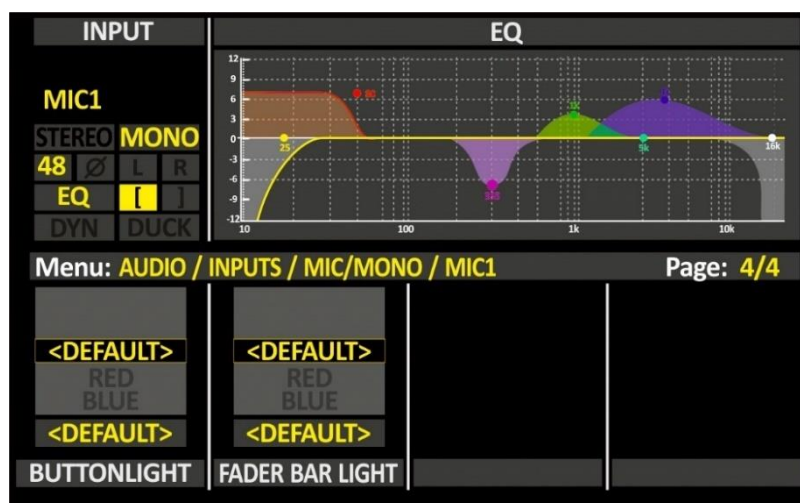
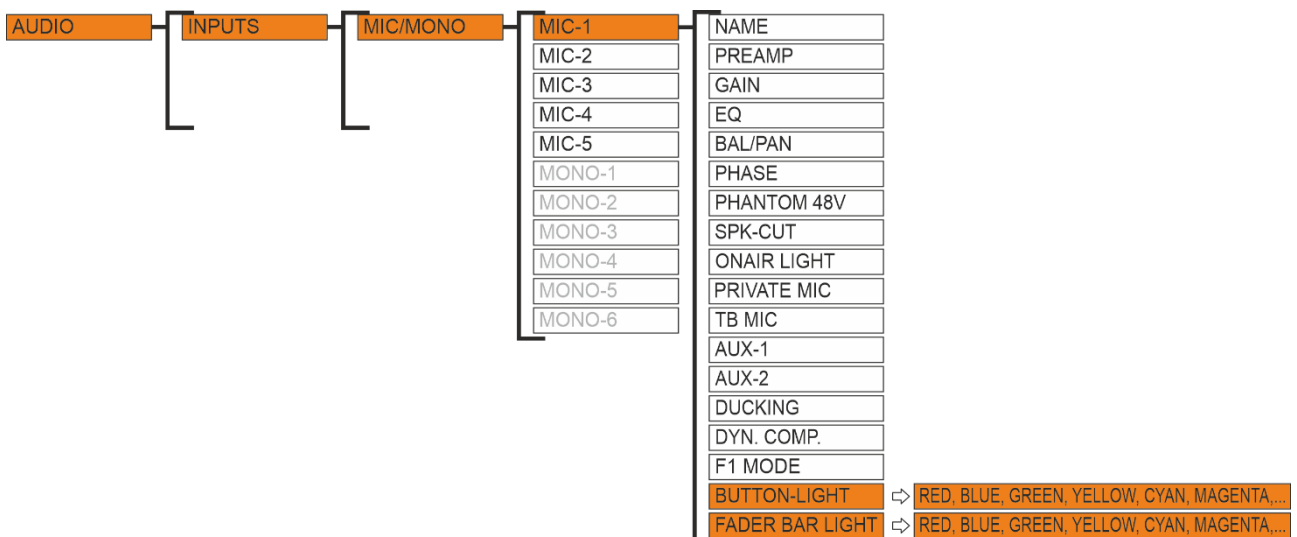

3.1.2 MIC-5 INPUT / TELCO INPUT

To use an external telephone hybrid, you must change the **MIC-5** to set it as a **TELCO** input. The telco input channel controls the connection to a telephone balance unit (or external hybrid). It has one balanced line-level mono input on **XLR**.

Can access these settings by following the next steps by rotating and pushing the navigation knobs.

MENU: MAIN / AUDIO / SETTINGS / INPUT MODE

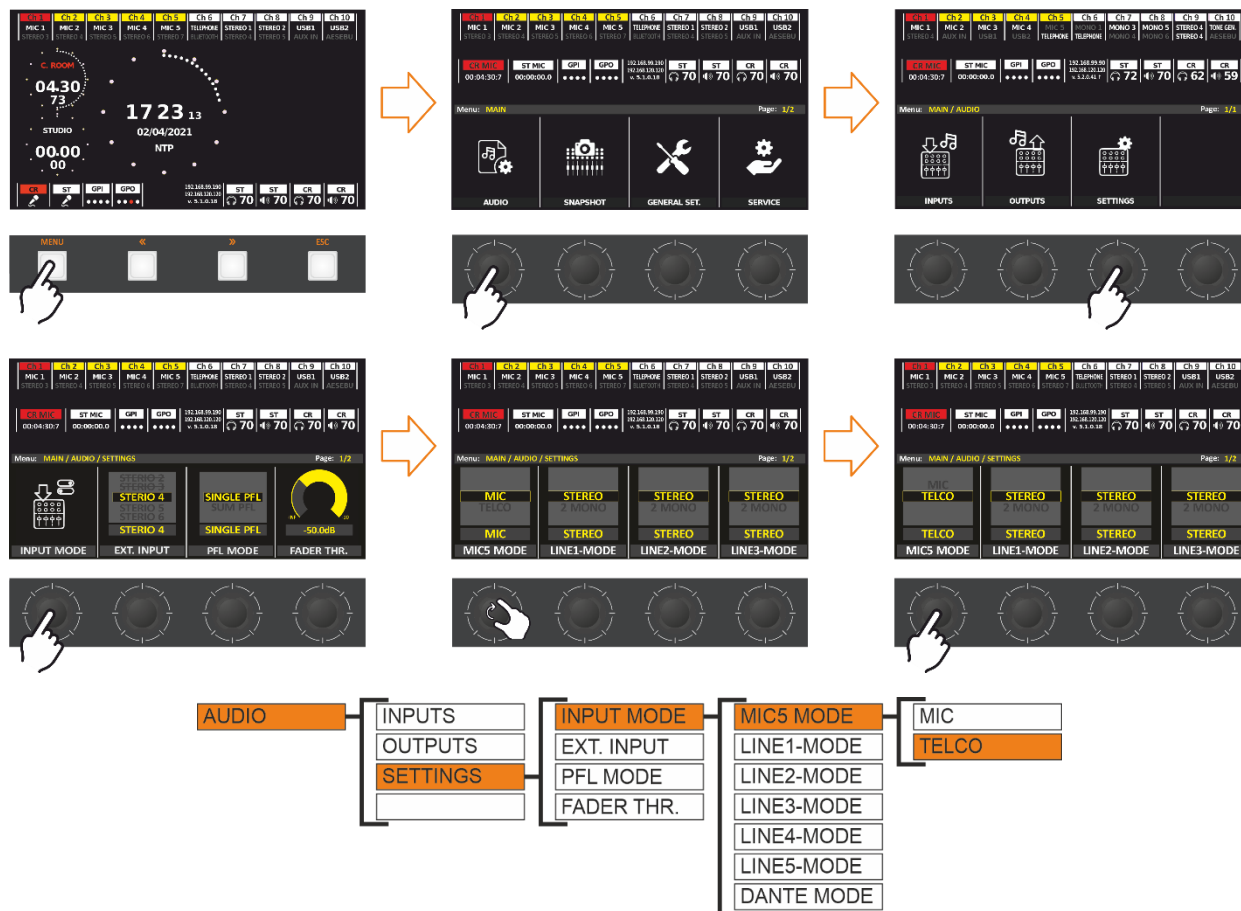

When you change the **MIC-5** to **TELCO MODE**, the **MIC-5** in the input microphones setting will show in a grey color to indicate **MIC-5** is inactive. Observe the following figure.

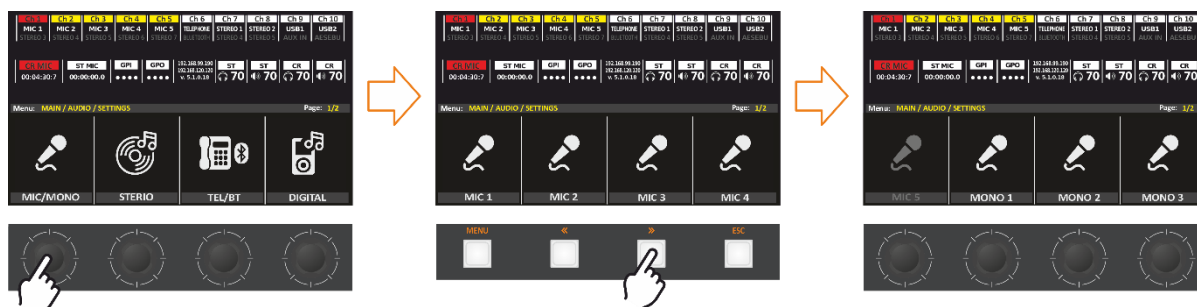

Be sure that is no channel using **MIC-5** as a source **A/B**. It is necessary to change the configuration from **MIC-5** to **TELCO**. If not, you will get an error message. EX: **Src MIC5 (as A or B) on channel 10**. Observe the next figure.

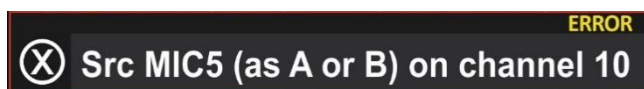

In this case, just goes to the intended channel source and change it from **MIC-5** to empty or any other choice.

To use the internal hybrid, connect the telephone line to the console **RJ11 LINE** port and the telephone set to the **RJ11 SET** port in the console.

If the line is well connected, you have to associate the **TELEPHONE IN** source to a Mixer Channel. When you will receive a phone call press **F1** of the selected Channel to hook the line.

By pressing **PFL** of the same source channel you can speak in private to the caller from the selected microphone as a **PRIVATE MIC**.

If you want to connect the **TELCO MODULE** with a third parties **hybrid**, we will send to you a scheme to create the special **DE9P** cable.

By pressing **PFL** you can speak in private to the radio listener (caller) with the **MIC1**.

NOTE: If the need arises to connect more than one **TELCO**, can be set **LINE 4** and **LINE 5** as a TELCO input. Then will get extra 4 TELCO inputs.

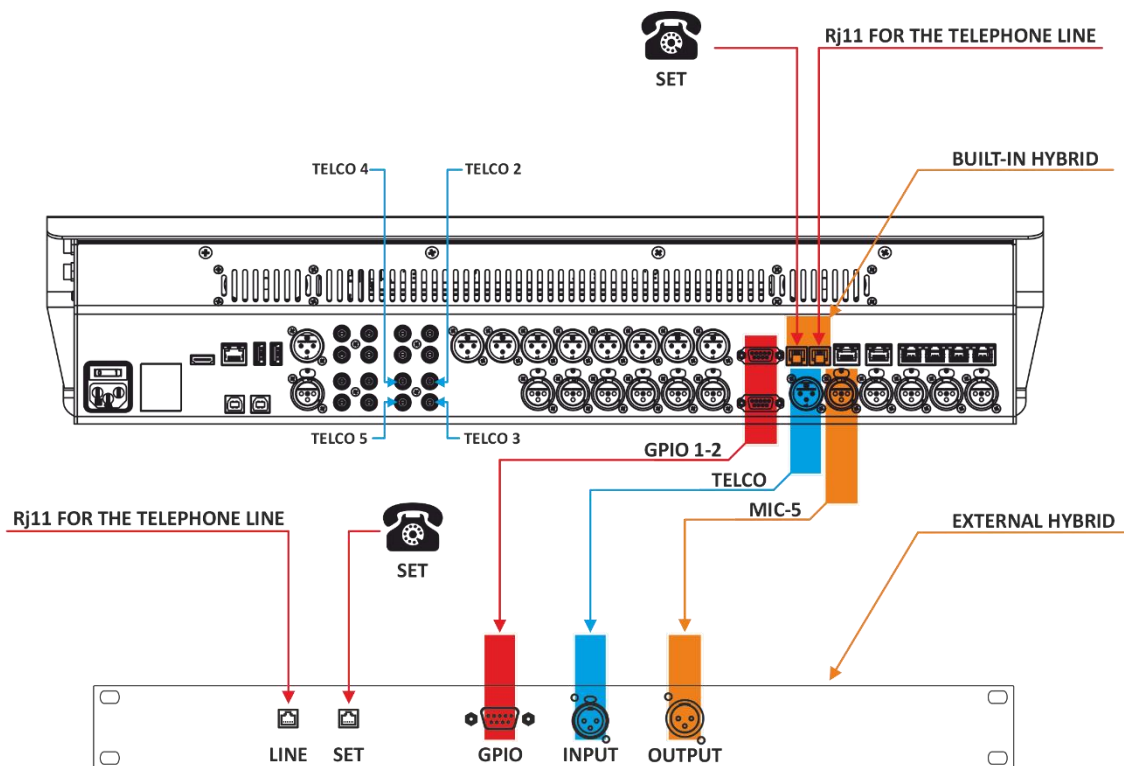
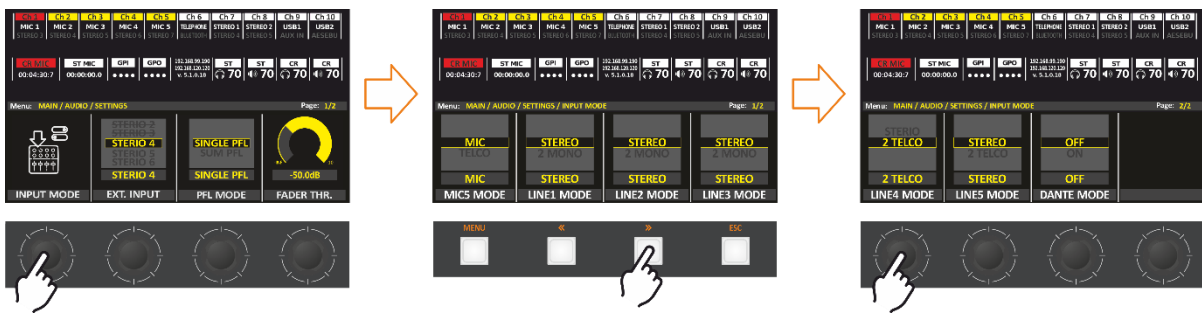

3.1.3 MONO-1 to MONO-6

Line-1, Line-2, Line-3

3 Stereo Input (L/R) / 6 Mono - XLR Female - Balanced Audio Connection (50KΩ).

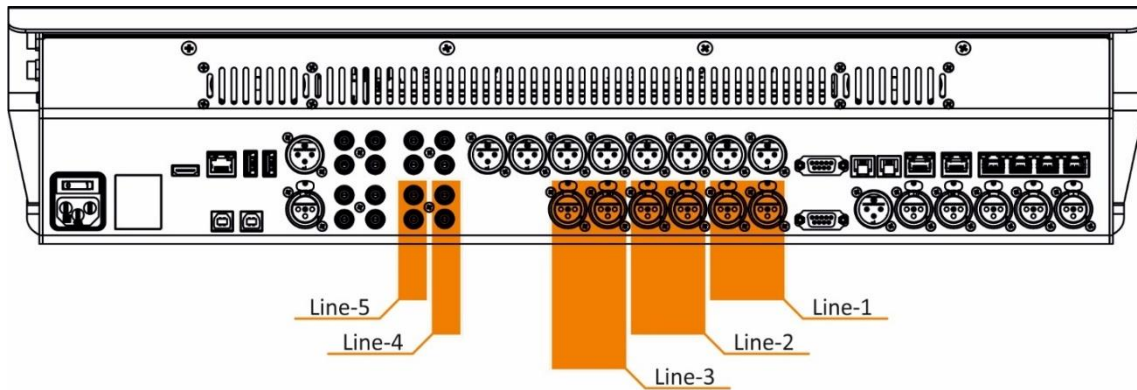

To browse the **MONO** source pages just click on the Next button (») in the **MIC/MONO** page as the next figure.

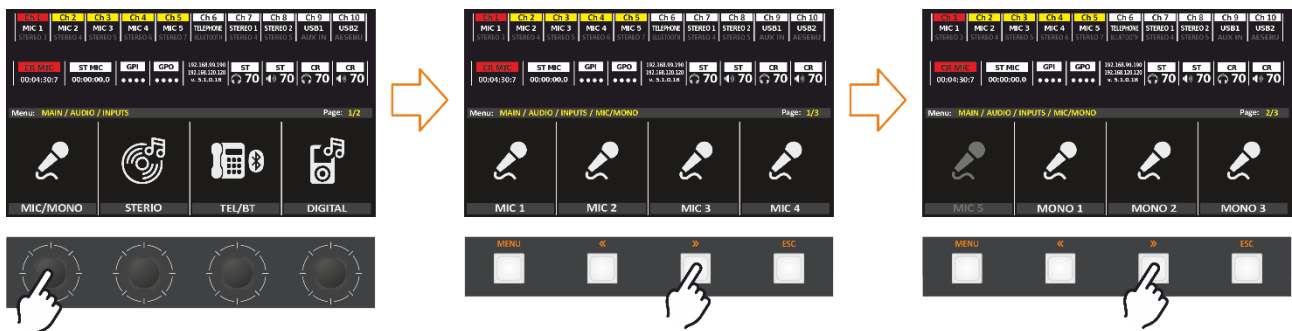

ATTENTION:

When the associated **STEREO** input is active, the **MONO** will be shown in an inactive mode.

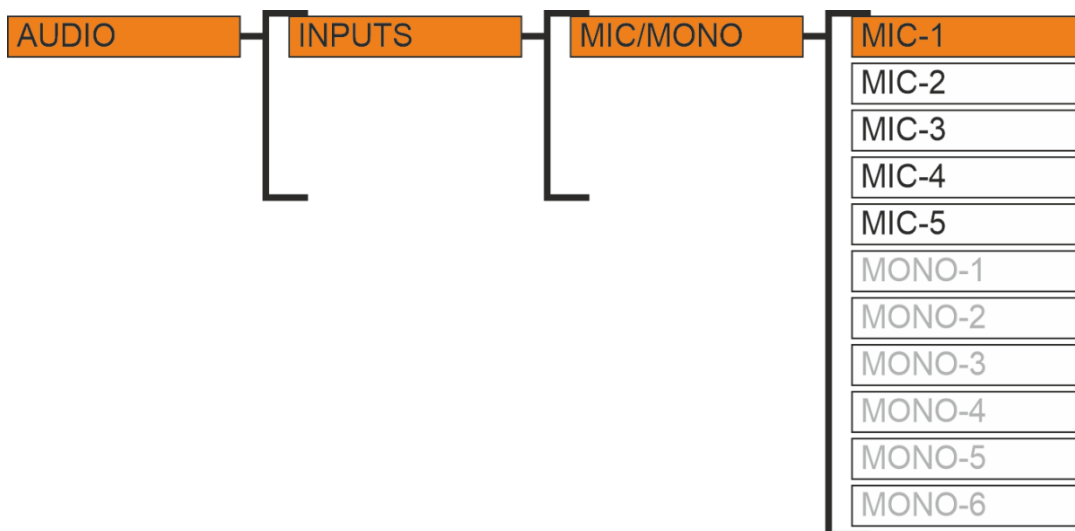

To change the source type from **MONO** to **STEREO** or on contrary you need to follow these steps: -
MENU: MAIN / AUDIO / SETTING / INPUT MODE

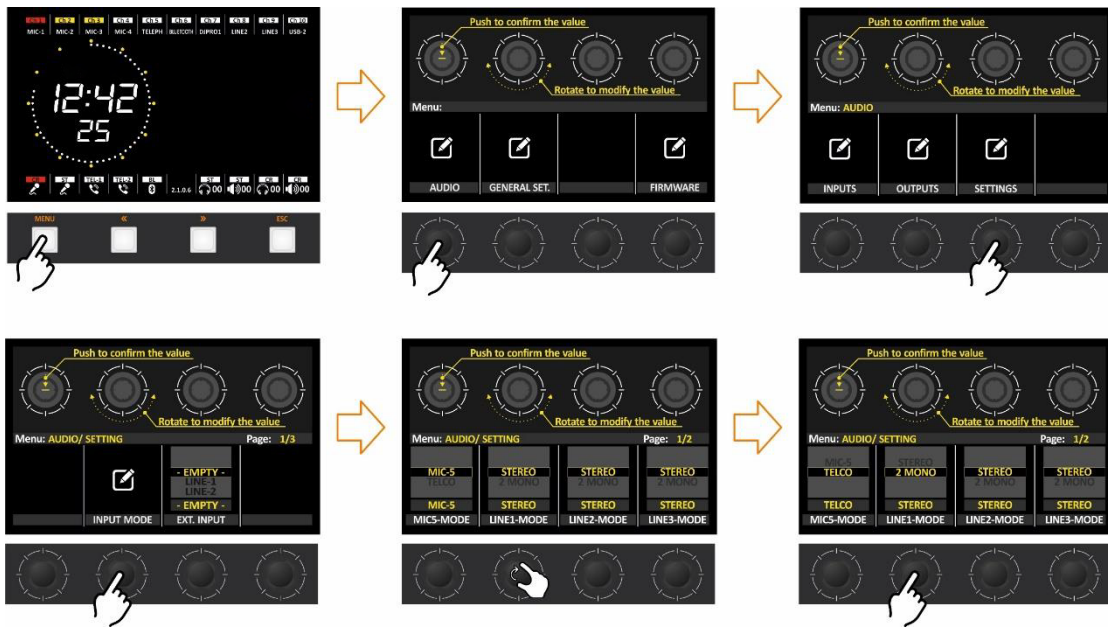

3.1.4 STEREO

You can set Input Stereo source parameters from the **MENU: AUDIO / INPUTS / STEREO** by PUSH/RUTATE the knobs as in the following steps.

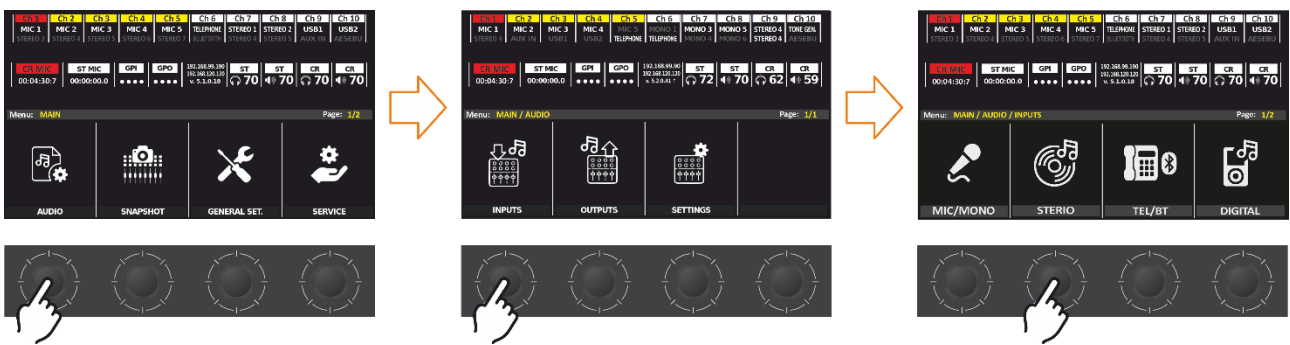

From this level of the menu, you choose which input **STEREO** source that you like to customize.

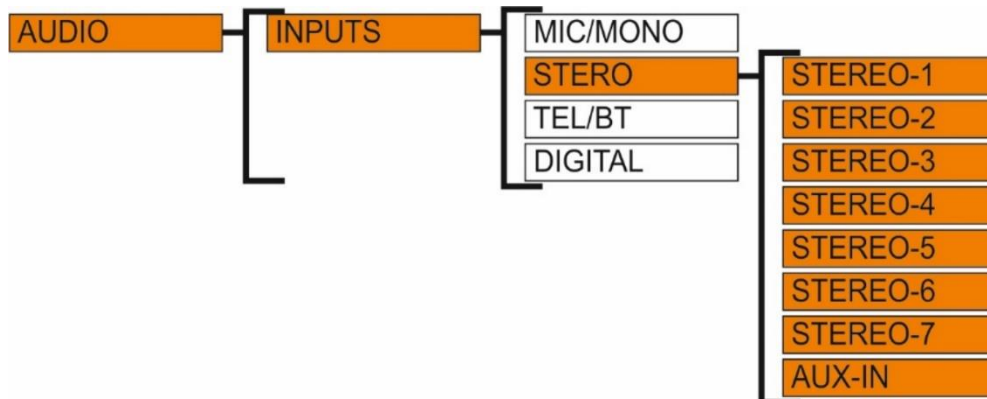

STEREO-1 to STEREO-7

Here we can find all **STEREO** source parameters (**STEREO-1 to STEREO-7**)

That can manage our 7 inputs like changing the **NAME**, **GAIN**, **PAL/PAN**, **EQ**, **AUX-1**, **AUX-2**, **BUTTON LIGHT**, and **FADER BAR LIGHT**.

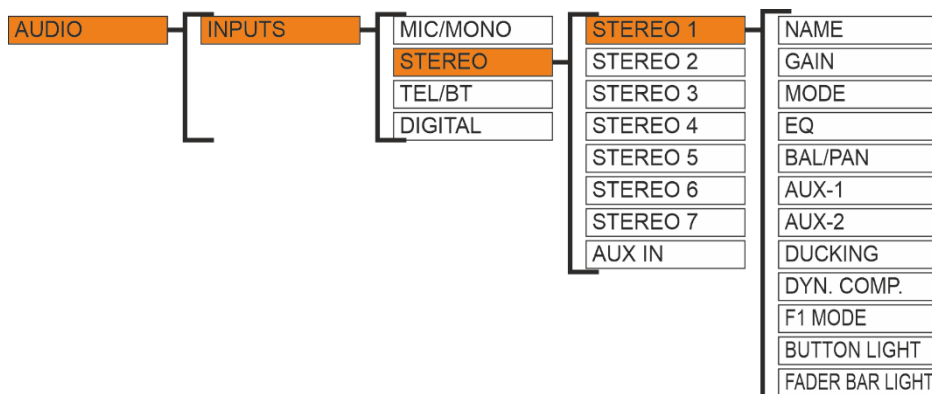
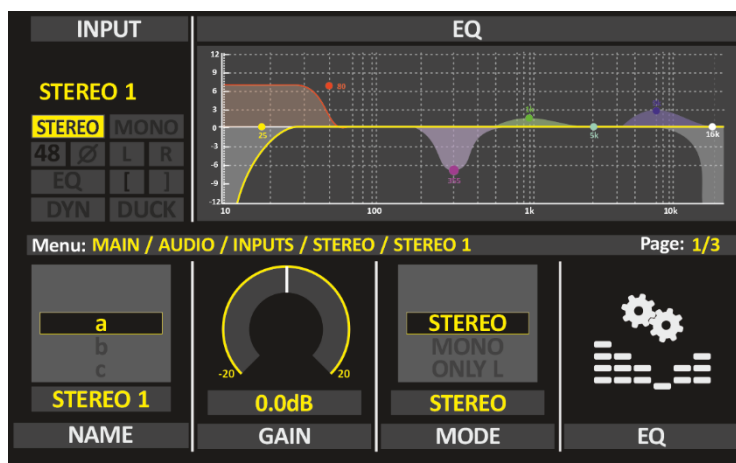

You have the possibility to set **AUX-1** and **AUX-2** to be **POST-Fader** or **PRE-Fader**, this choice is of every single channel.

ATTENTION: When you set **AUX-1** and **AUX-2** to be **PRE-Fader**. The **FADER** does not affect the **AUX** output signal in this case.

3.1.5 AUX-In

Stereo Input - Mini Jack 3.5mm - Unbalanced Audio Connection.

An aux-in (or auxiliary-in) socket is a 3.5mm jack into which you can plug anything that has a standard headphone connection. It's enabling you to 'stream' music from a device like a **Phone** or **Music Player**... etc. through the console.

We set it in the side position to be comfortable connect any device.

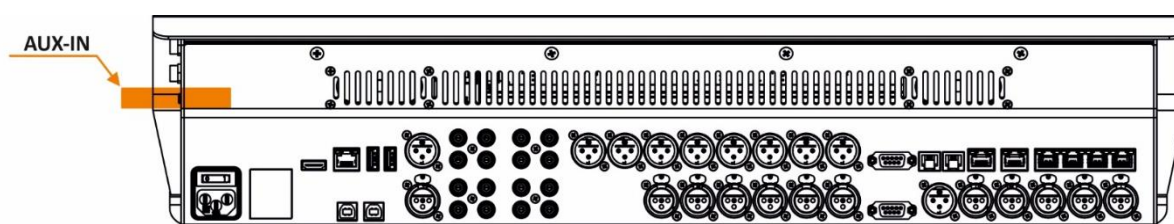

3.1.6 TEL/BT

These three different kinds of implementations were been grouped all together. In fact, they have similarities on the source side.

3 kind of telephone connection is available on the Digital console:

- **TELCO** (external telephone 📞 hybrids)
- **TELEPHONE** (internal telephone 📞 hybrids)
- **BLUETOOTH** (smartphone 📱 call & player)

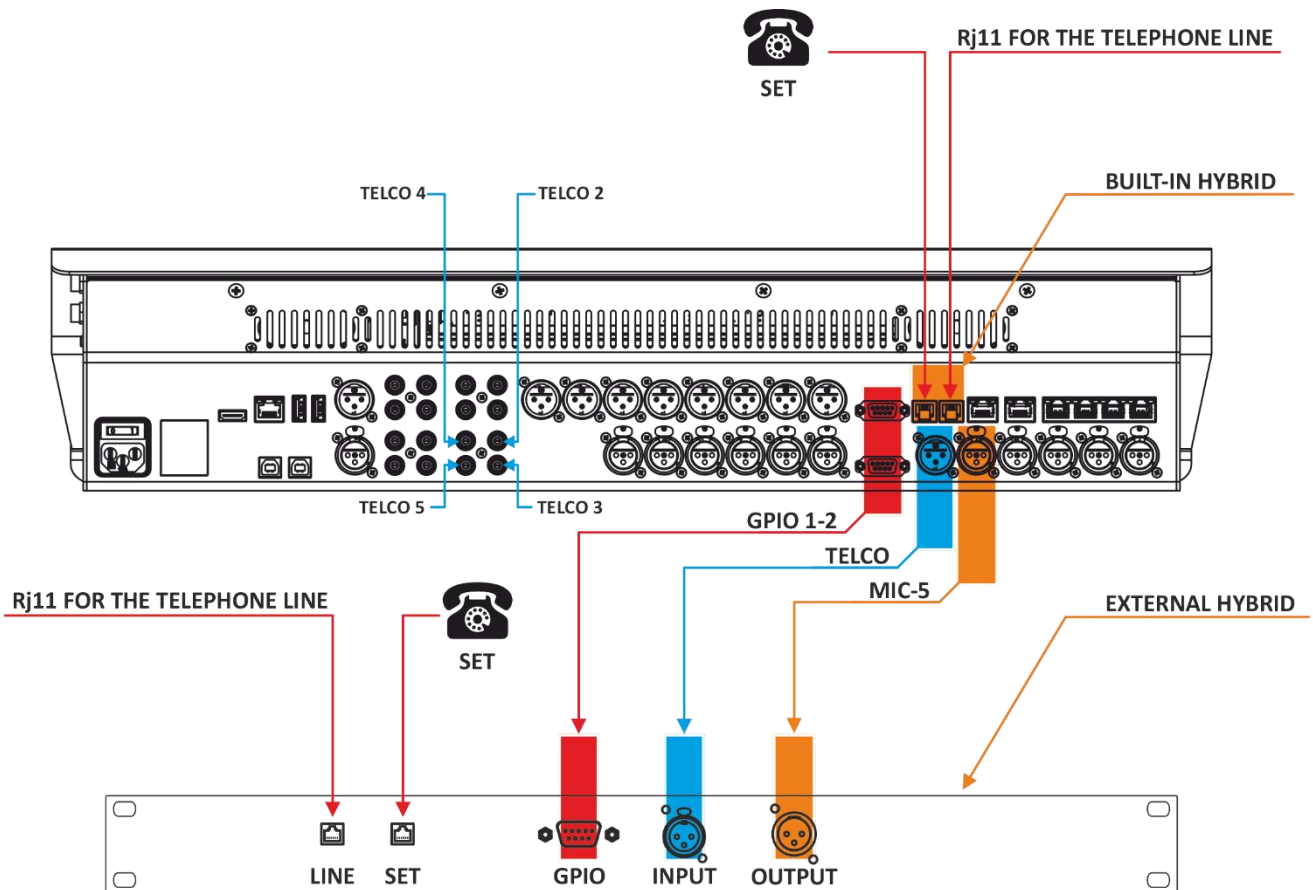
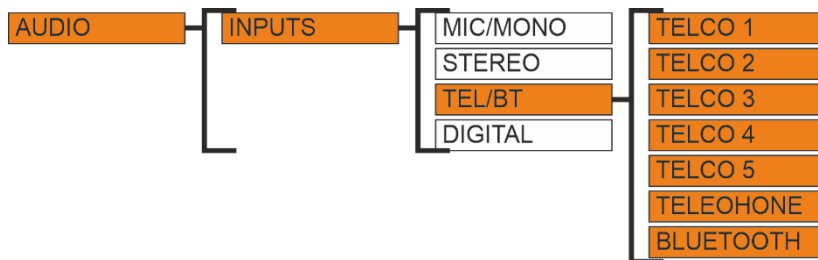

Telco

Telco N-1 in/out, to connect to an external telephone hybrid.

The output **Telco N-1** is always available on the **XLR male** connector, while the input receiving line is mutually shared with **Mic-5**.

It's available a **4 inputs/outputs N-1** on inputs **STEREO 4/5** and outputs **REC 1/2** are also available without **GPIO** controls and **GPIO OVER IP** (TCP/IP communications).

Telephone Hybrid

The **built-in telephone hybrid** allows direct connection of a telephone line **POTS/PSTN** on **RJ-11C**. The audio is processed via DSP that delivers state-of-the-art audio processing.

TLC commands are available on a **SubD** connector with **Hook and Ring** interface for an external telephone hybrid.

Now, we are going to analyze a normal call (in example with the internal telephone hybrid):

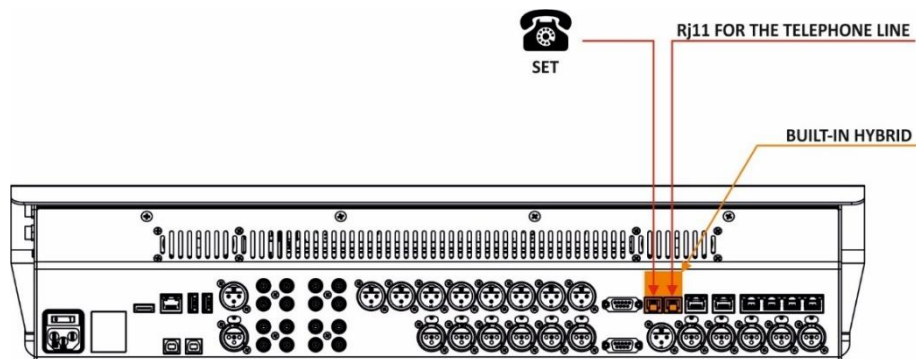

In the presence of an incoming call, the **F1** button starts blinking.

By pressing **F1** it will hook the call.

- F1 LED **off** – the line is not hooked.
- F1 LED **blinks** – RING – there is an incoming call.
- F1 LED **on** – the line is hooked.

By pressing **F1** again you drop the line.

NOTE:

- * The behaviour of (RING/HOOK) is the same for the three interfaces (TELCO, HYBRID, and BLUETOOTH).

Once a phone call is hooked the received audio is managed like all other sources, **PFL/BUS** works standardly.

Differently, from normal sources, these three telephone sources need to send back an audio **TX** to the caller/radio listener.

The **TX** audio has two different functioning ways:

- 1 – private mode (with channel **PFL=ON**). In this case, all output buttons will be plinking because they will be in isolation from this source.
- 2 – On Air mode (with channel **PFL=OFF**).

That can control the **GAIN TX** from the menu to decrease or increase the TX audio gain “output to the caller”. It’s easy to adjust it between **-20 dB** to **20 dB** by rotating the **GAIN TX** knob. The step of the adjustment is **0.1 dB**.

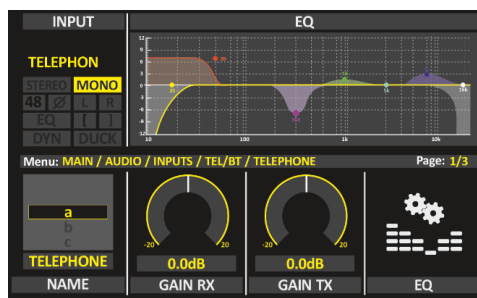

When you want to speak privately with a caller just press the **PFL** in the TELEPHONE line channel.

PRIVATE MIC is the input dedicated to the communication with the caller. Like the Talkback, it is not ruled by the **ON/START** button or by the fader level.

The private mic is the microphone that can talk to the caller privately and this conversation is not audible in the loudspeakers and MAIN outputs.

It can set one or more private microphone by going to: -

MENU: MAIN / AUDIO / INPUTS / MIC/MONO

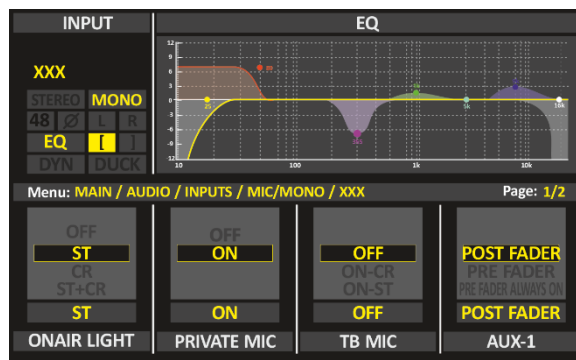

F1 MODE:

From here, you can change the way the **F1** button communicates with the external hybrid and can select one of three choices available (**NONE**, **GPIO**, **DEVICE**)

NONE: no action.

GPIO: F1 button communicates with the external TELEPHONE HYBRID by the traditional general-purpose Input/Output.

DEVICE: F1 button communicates with the external TELEPHONE HYBRID by the **GPIO over IP**. That gave the possibility to communicate with an external telephone hybrid via ethernet.

If you select **DEVICE**, you have to go to set the IP of the external telephone hybrid: -

MENU: MAIN / AUDIO / INPUTS / TEL/BT / TELCO 1-5 / DEVICE

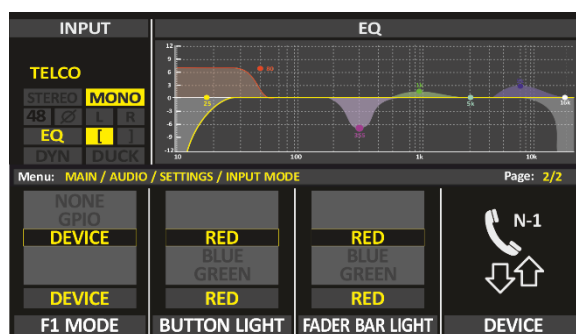

Bluetooth

The table has a Bluetooth connection. This allows airing the calls made via Skype, Viber, Whatsapp, or normal phone calls by a Smartphone 📱 and Tablet.

The consol has two modes of Bluetooth connection:

- Mono Bidirectional to support phone calls.
- Stereo monodirectional for streaming high-quality stereo audio (A2DP). This feature allows airing the music from smartphones and tablets.

3.1.7 DIGITAL

Digital Mixing Console has included digital audio I/O sources. By the digital audio, it can connect any digital audio source via **AES/EBU, USB, Dante**.

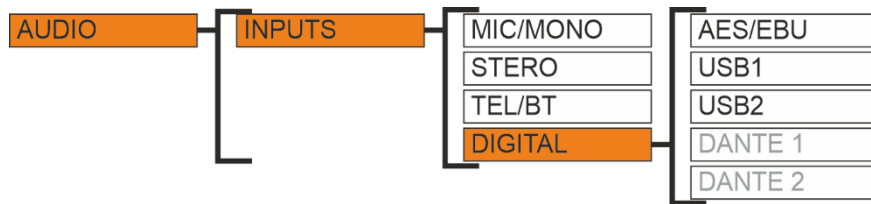

AES/EBU

Stereo Input - **XLR** Female - Balanced Digital Connection (110Ω).

USB-1, USB-2

Two USB audio interface

The USB audio interface allows to directly connect the PC to the console, with no need for audio cards: in fact, the PC detects the console as a digital audio card with 2 stereo inputs and 2 stereo outputs for simultaneous playout and recording.

two Built-in stereos **USB I/O** Audio Interface to connect directly to a computer. USB Audio Card with a connector **Type-B**. With this type of connection, you can save hundreds of dollars on an audio card. By Digital Mixing Console, you can connect your computer or any digital device via perfect USB audio I/O sources.

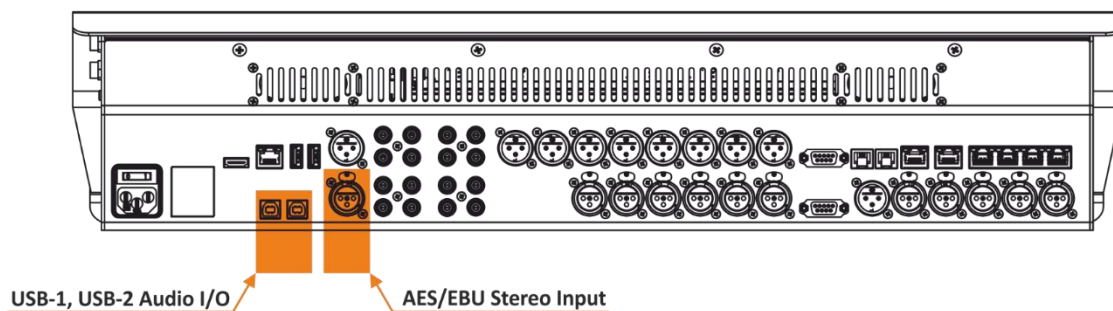

Once the mixer is connected to a computer, it will be recognized automatically and will not require any intervention. The connection is made via normal **USB-B cable 2.0**

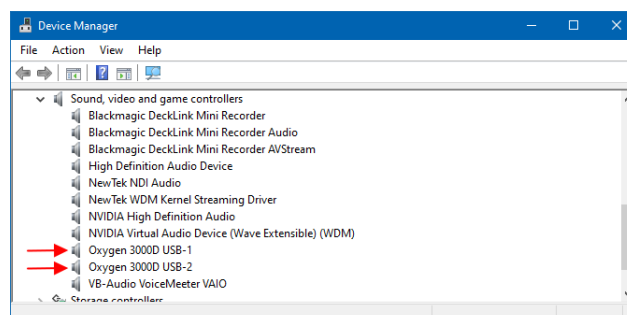

NOTE: Highly recommend that not use a (**SS 10**) SUPERSPEED USB port on the PC side.

SuperSpeed USB
Trident Logo



SuperSpeed USB
10 Gbps Trident Logo



To set the parameters correctly, we have to leave the **output/playback** as default (**48000 Hz**).
For the **input/recording**, we have to change the frequency to (**44100 Hz**).

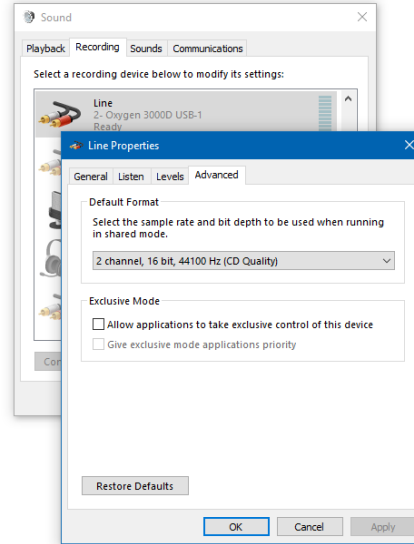
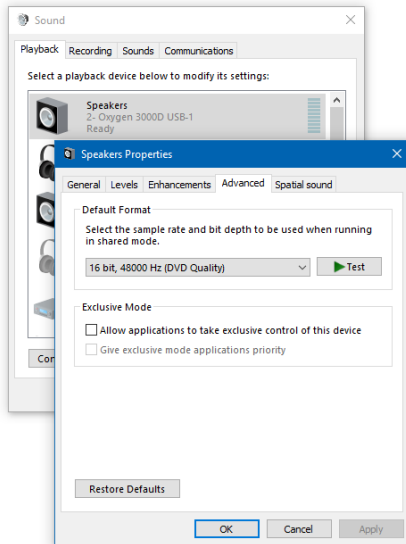

* DANTE 1, DANTE 2

DANTE AUDIO-OVER-IP CONNECTIVITY (Optional)

Dante option (compliant with AES67) provides an Ethernet connection for 2 Stereo Input and 2 Stereo Output, with independent and dedicated Level Control and Sample Rate Conversion.

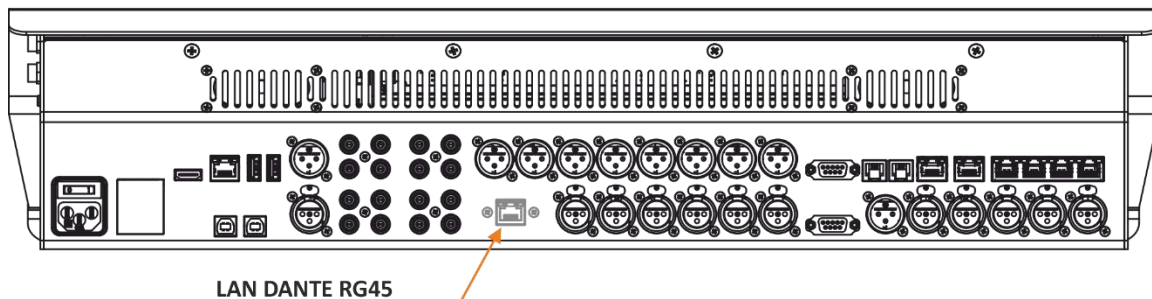

* Optional.

3.2 AUDIO/OUTPUTS

Digital console is coming with variant audio outputs connectors like **XLR**, **JACK**, **USB**, and **RCA** to give you maximum flexibility with your instruments and your project cabling. With all those functions you can save your time and your money. As well as the creative USB connection, we don't need a sound card or a professional instrument to connect any media player or recorders like a **PC**, **Workstation**, or **laptop**.

Outputs included:

- **4 Stereo Output - XLR Male - Balanced Audio Connection (47Ω).**
- **4 Stereo Output - PIN RCA - Unbalanced Audio Connections.**
- **2 USB Audio Card USB -Type B - PC Connections.**
- **2 Stereo Output - Jack 6.3mm - Unbalanced Audio Connection (nominal 32Ω).**
- **6 RJ45 (SFTP Cable) audio and GPIO connections.**
- **AES/EBU Stereo Output - XLR Male - Balanced Digital Connection (110Ω).**
- **Analog Telephone Line - RJ11 - PSTN Interface**
- **Bluetooth Stereo/Mono Output - Wireless – Smartphone.**

You can set outputs parameters from the **MENU: MAIN / AUDIO / OUTPUTS** by **PUSH/RUTATE** the knobs as in the following steps.

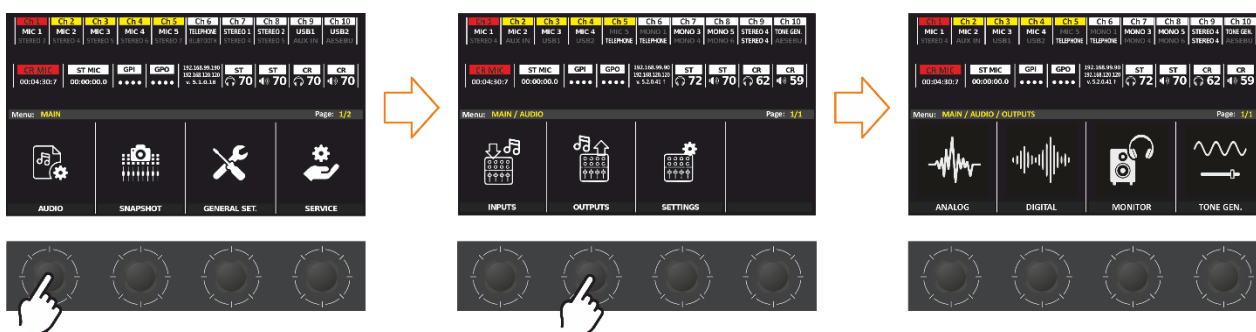

From this level of the menu, you choose which output that you like to customize.

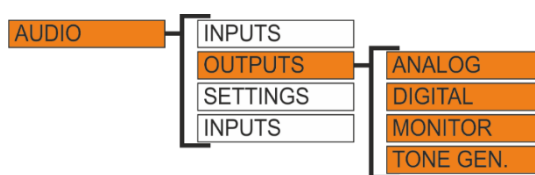

3.2.1 ANALOG & DIGITAL outputs.



From this level of **MENU**, you can customize the main outputs. In this section, you can select the main output source type, gain, and mode.

It's also able to adjust the audio output level by the **GAIN** knob. The gain has steps of **0.1 dB**. The audio output **GAIN** range goes from **-6 dB** to **6 dB**. From **MODE** can select the output type like **STEREO**, **MONO**, **MONO LEFT**, or **MONO RIGHT**.

N.B.: When the parameter control is activated, in real-time the parameter value is updated, perceiving the increase and decrease of the **GAIN**, the graphics will change from yellow to white until the parameter is confirmed.

3.2.2 MONITORS

SPK-CRM & SPK-STUDIO

- This section is used for the management of the loudspeakers.
- The rotary control knobs allow you to amplify/attenuate the audio level.
- The loudspeakers audio level goes from **0** to **99** is the maximum allowed level. Can set the maximum level by going to this page:
MENU: MAIN / AUDIO / OUTPUTS / MONITOR / SPEAKER
- The step of the loudspeaker's adjustment is **1 dB** and the level goes from **-80 dB** to the maximum of **+19 dB**.
- By pressing the knob, you can mute  or play the control room speakers if it is already muted.
- To unmute the speaker  just press their knob or **increase/decrease** the audio level by rotating the knob and confirm that by clicking on the same knob.
- The loudspeakers level is displayed in the bottom-right section of LCD.

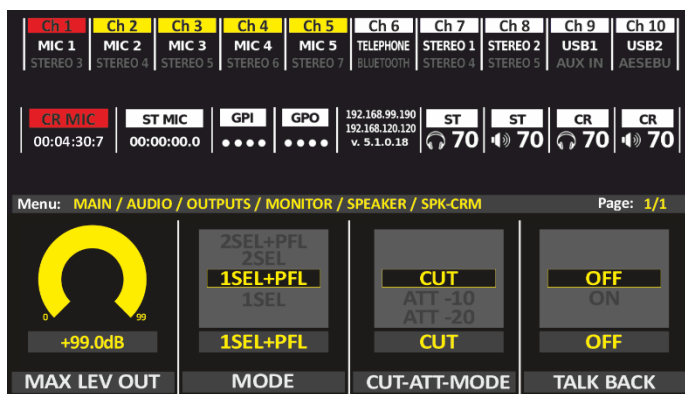

MODE: 1SEL, 1SEL+PFL, 2SEL or 2SEL+PFL

PFL (pre-fader listening): This mode allows you to listen in loudspeakers to the audio of the single-channel **before** the intervention of the fader.

1SEL (one selection): This option allows you to listen in speakers to only ONE selected output from output section ④ (PGM, SUB, AUX1, AUX2, EXT).

1SEL+PFL: This mode allows you to listen to **ONE selected output** or **PFL** if press the button  PFL of one channel.

2SEL (two selection): This option allows you to listen to ONE selected output ④ (PGM, SUB, AUX1, AUX2, EXT), And by pressing the **SPK** button ② you will be able to listen to different output in loudspeakers.

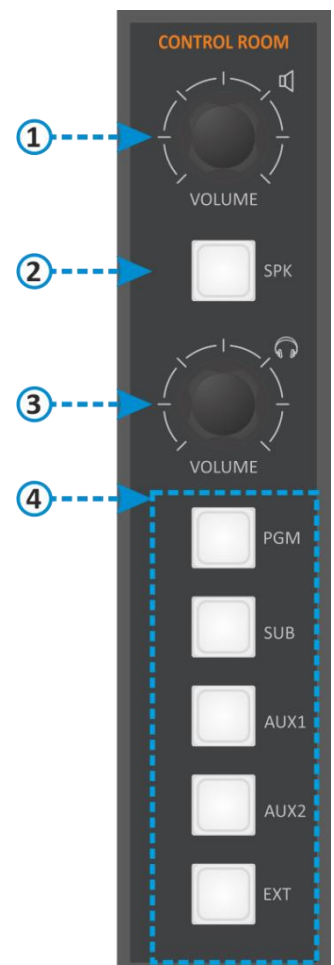
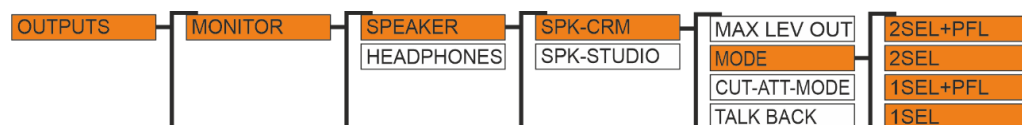

EX.: if you need to listen to different output in **SPK-CRM** Control Room Speakers, select the **2SEL** mode from the setting and press the **SPK** button in section ② (it will show up in warm color), that press any other output button from section ④ (it will show up in warm color) to hear that output in the speakers only. (see the next figure).

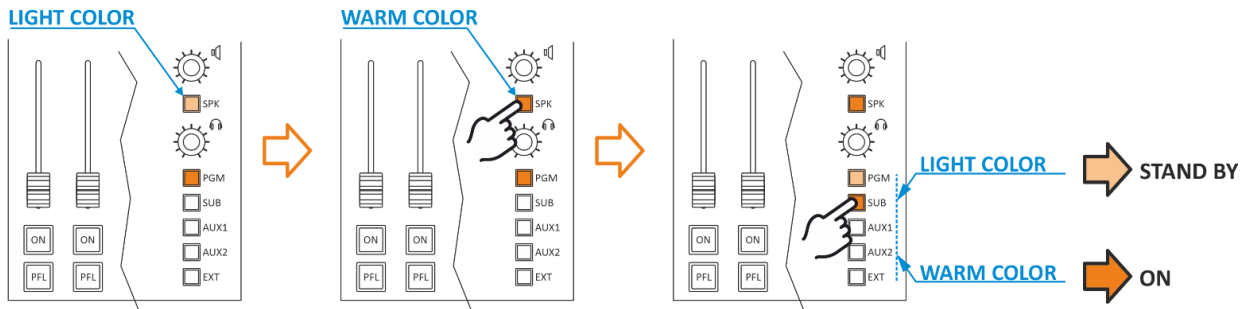

2SEL+PFL: It is a similar mode to the above-mentioned case, in addition to that you can hear the **PFL** in a bout of headphones and speakers simultaneously. (see the next figure).

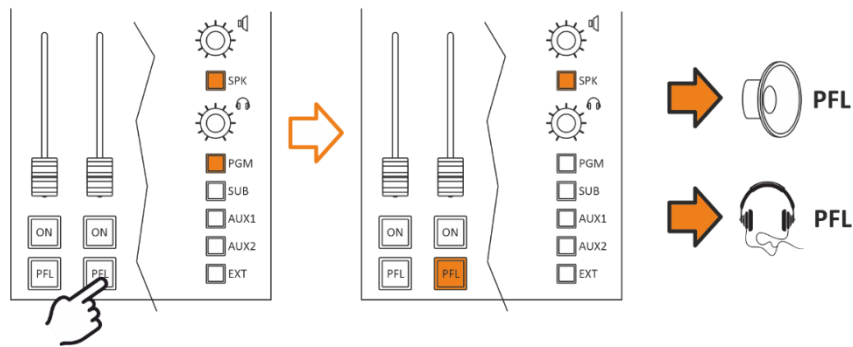

CUT-ATT-MODE

It's allowed the microphone to **CUT OFF** the audio of loudspeakers once the microphone goes to ON. The opening of a microphone channel (if configured appropriately) can generate the closing command of the loudspeakers.

That is possible to choose one or more microphone to cut the loudspeaker output of them by following this path:

MENU / AUDIO / INPUTS / MIC / SPK-CUT (OFF, ST, CR, CR+ST)

When you select **CR**, press down the knob to confirm the selection and the **CR** will show up in yellow color.

When you open the associated source with a **CUT** function you will see it will **MUTE** CR Loudspeakers output to prevent LOOP audio and the SPEAKER icon at LCD will start plinking.

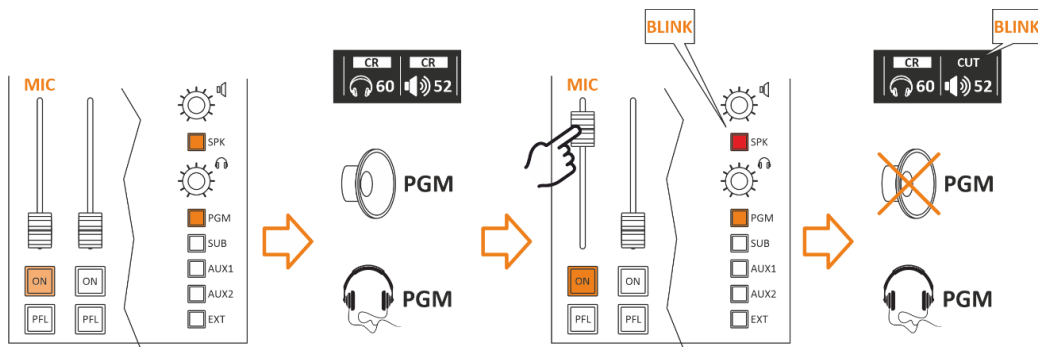

ATT. (attenuation) MODE: It helps reduce acoustic flux from flowing into the speakers. It is possible to decrease the speakers output -40, -30, -20 or -10 dB.

EX.: If we want to reduce the sound coming out of the speakers by **40 dB** less than the current value, then we have to choose **-40**. The same thing if we want to reduce the current volume when opening any of the microphones with a value of **10** decibels, then we have to choose **-10** and confirm the selection by pressing the button around until the selection color changes to yellow.

The **CUT** mode is triggered by the change from **OFF** to **ON** of a microphone source to which it has been set closing of the loudspeaker.

As shown in the MENU this function (**CUT**) is associated only with the loudspeakers, to avoid LARSEN effects "feedback loop" from occurring between the nearby loudspeakers and On-Air microphones.

On the other hand, If you need to **MUTE** the loudspeakers manually just **PRESS** the volume knob down. **PRESS** the volume knob a second time or rotate it to activate the loudspeakers output and amplification or attenuation. The status of **MUTE-SPK** is indicated by a red cross on the SPEAKER icon.

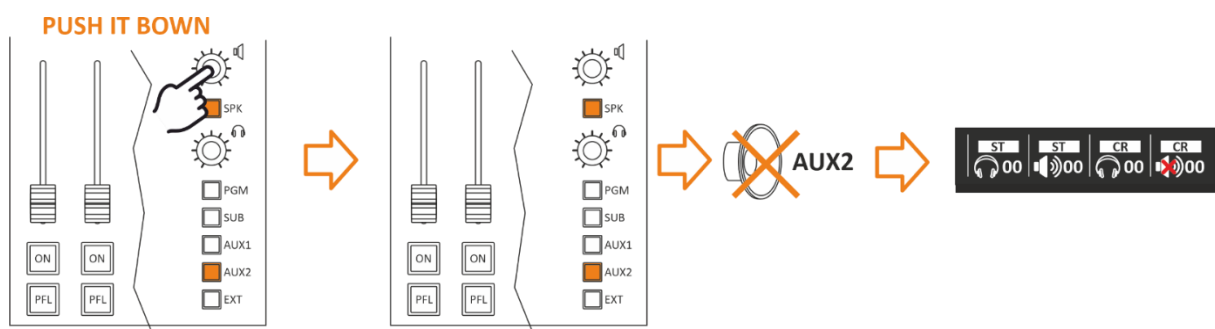

TALKBACK

MENU / AUDIO / OUTPUTS / MONITOR / SPEAKER / SPK-CRM / TALK BACK (OFF, ON)

Here where can **disable/enable** the **TALKBACK** communications in speakers output. Normally the talkback is used to communicate between the mixer man and the people in the studio via headphones. This option gives you the possibility to hear the people talking in TALKBACK in the loudspeakers.



In the case of the **SPK-STUDIO**, you can choose from **TB1** and **TB2** to select which **TALKBACK** button will be associated with the STUDIO loudspeakers.

HDP (headphone) CRM, STUDIO & GUEST

This section is used for the management of the headphone.

- The rotary control knobs allow you to amplify/attenuate the audio level.
- The headphone's audio level goes from **0** to **99** is the maximum allowed level. Can set the maximum level by going to this page:

MENU: MAIN / AUDIO / OUTPUTS / MONITOR / HEADPHONES

- The step of the headphone's adjustment is **1 dB** and the level goes from **-80 dB** to the maximum of **+19 dB**.
- By pressing the knob, you can mute  or play the control room speakers if it is already muted.
- To unmute the speaker  just press their knob or **increase/decrease** the audio level by rotating the knob and confirm that by clicking on the same knob.
- The headphones level is displayed in the bottom-right section of LCD.

If you need to **MUTE** the headphone just **PUSH** the volume knob.

PUSH the volume knob a second time or rotate it to activate headphone output and amplification or attenuation.

The status of **MUTE-HDP** is indicated by a red cross on the **SPEAKER** icon.

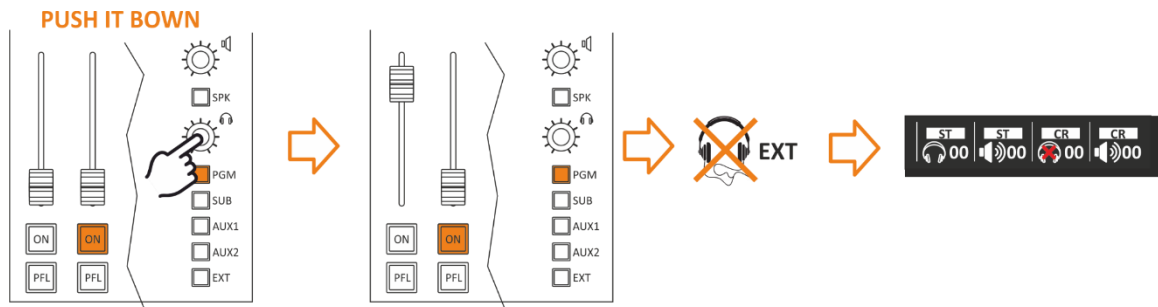

SEL (one selection): This option allows you to listen in speakers to only ONE selected output from the output section (PGM, SUB, AUX1, AUX2, EXT).

SEL+PFL: This mode allows you to listen to **ONE selected output** or **PFL** if press the button  PFL of one channel.

Normally Headphones listen to the selected source like the speakers.

If **PFL** is pressed, headphones can listen for it.

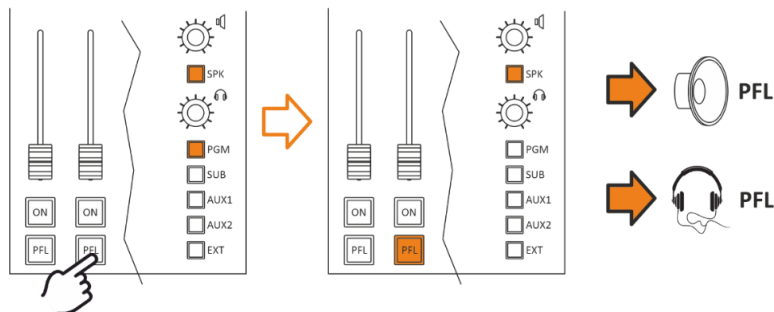

In the case of the **headphone STUDIO & GUEST**, you can choose from **TB1** and **TB2** to select which **TALKBACK** button will be associated with the STUDIO loudspeakers.

LINK MODE

By this function, it can associate the STUDIO headphone audio with the same audio sent to the MCR headphone.

3.2.3 TONE GEN. (TONE GENERATOR)

Digital Console comes with a built-in audio tone generator. The tone range is **30 Hz - 20 kHz** and you can select it by following these steps: -

MENU: MAIN / AUDIO / OUTPUTS / TONE GEN.

This option is too useful for the tuning instruments, science experiments, testing audio equipment (how low does my subwoofer go?).

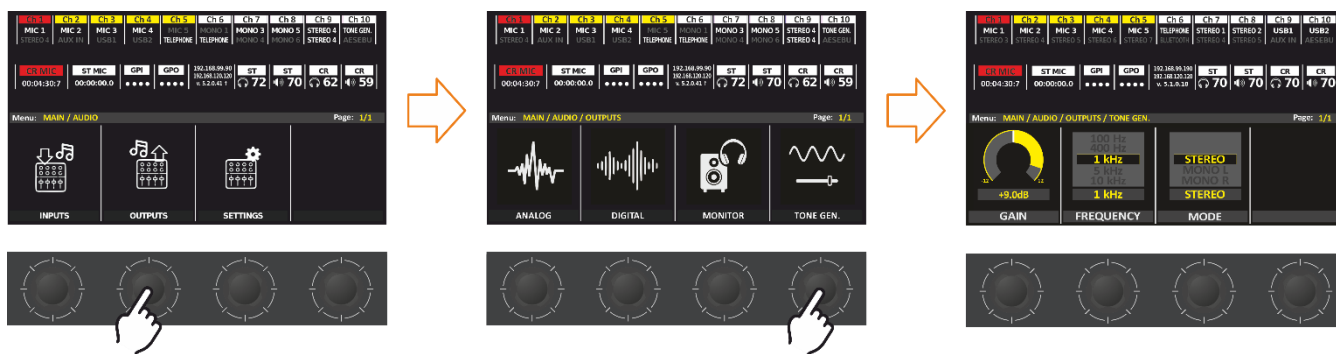

3.3 SETTINGS

INPUT MODE

Here we can choose the mode of input sources and we can each one of them like **STEREO** or **2 MONO**.

Also, we can change the **MIC-5** input to the **TELCO** input by following these steps: -

MENU: MAIN / AUDIO / SETTINGS / INPUT MODE.

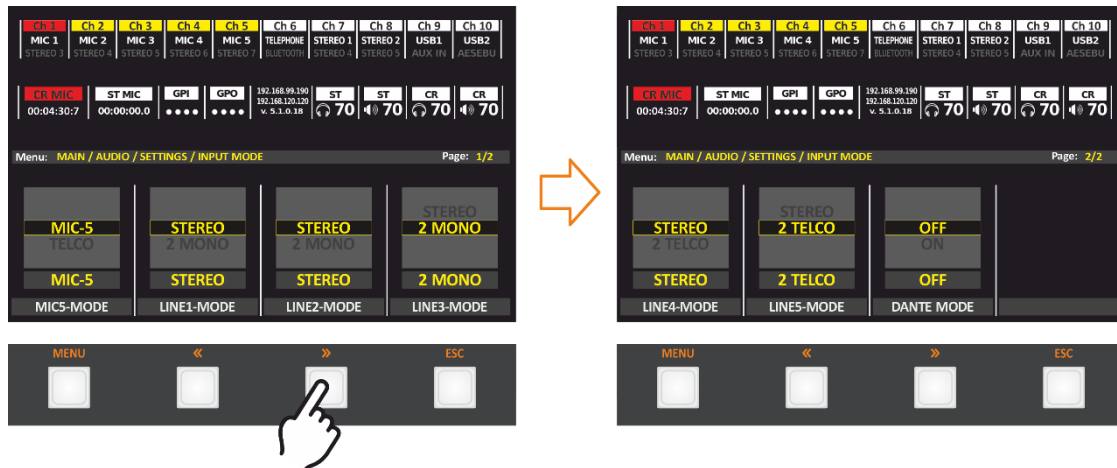

EXT. INPUT

From this page of **MENU**, you can set the **EXT.** input source. This function uses to send the **EXTERNAL LINE** input (TUNER) to the **STUDIO** or **CONTROL ROOM** loudspeakers like by the **EXT** button. You can select the **TUNER** source as to where is it connected to the mixer from the list of **LINEs** by following these steps: -

MENU: MAIN / AUDIO / SETTINGS.

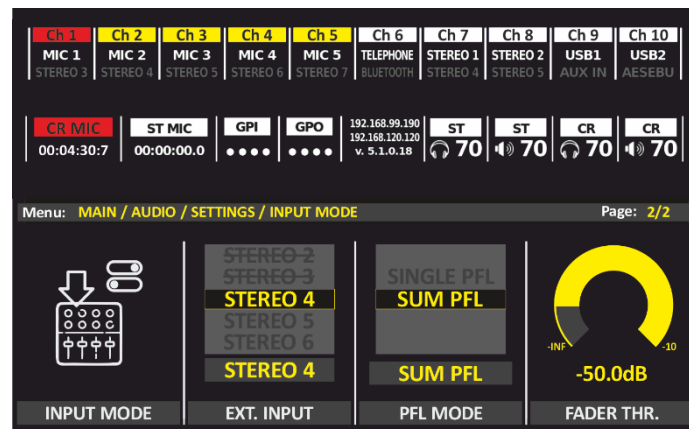

PFL MODE

SINGLE PFL: Only one PFL can be selected for listening.

SUM PFL: Can select multiple PFL to listen to all of them simultaneously.

SNAPSHOT

This function is useful to save and recall the settings. These settings are saved at the internal memory and it is not exportable.

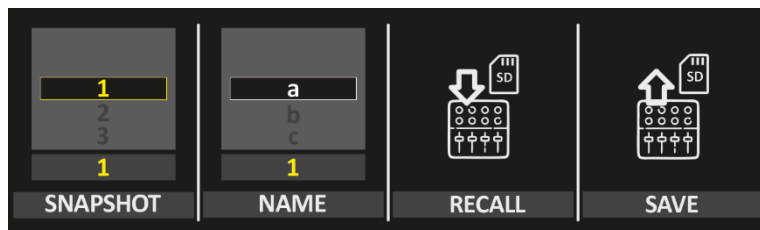

SNAPSHOT: it's able to save ten different PRESETS by select the position of the new save from 1 to 10 before save it.

NAME: here is can change the name of the PRESET to identifying them.

RECALL: to recall one of the PRESETS that already saved in internal memory.

SAVE: to save the actual setting as a **PRESET**.

AUDIO/SETTINGS/VJPRO

CTRL-SOURCE: The **DJPro** (Radio side) audio source is rooted automatically in the PGM. We suggest you select **USB AUDIO-1**.

SOURCE-1: First **VjPro Console** (TV side) audio source, in this channel you have a clip related to the DjPro song. The Audio rooting is specified by the last BUS-SOURCE parameter. We suggest you select **LINE-4**.

SOURCE-2: Second VjPro Console (TV side) audio source, in this channel you have a preloaded clip of the LINE-4 next clip. Useful source if the radio song length is shorter than the TV clip length. The Audio rooting is specified by the last BUS-SOURCE parameter. We suggest you select **LINE-5**.

BUS-SOURCE: General TV audio BUS for SOURCE-1(LINE-4) and for SOURCE-2(LINE-5). We suggest you select **AUX-1**.

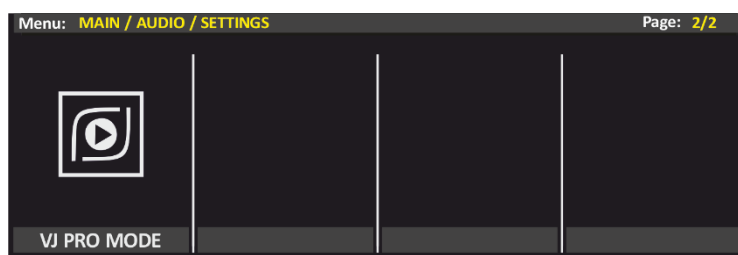

3.4 GENERAL SET.

GPIO

Here we will talk about only the physical **GPIO** connections. You can find the **GPIO over IP** in the **TELCO** part.

The console is coms with **two SUB-D 9pin (DE-09)** as a connector of general-purpose input/output (**GPIO**).

Each one of these two connectors is equipped with two programmable **GPI** and two programmable **GPO**. It is also supplied with **+5v**.

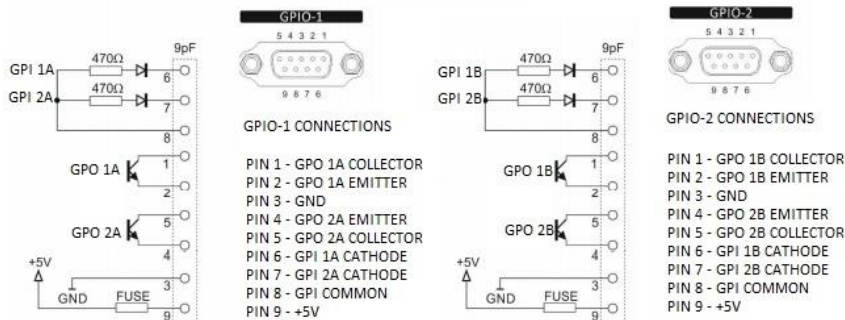
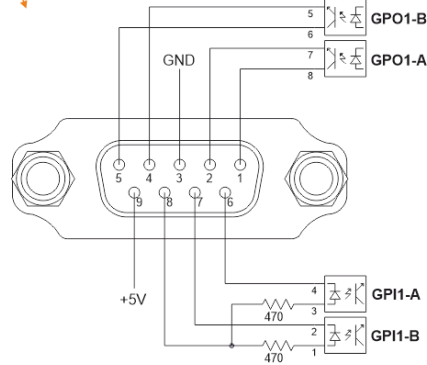
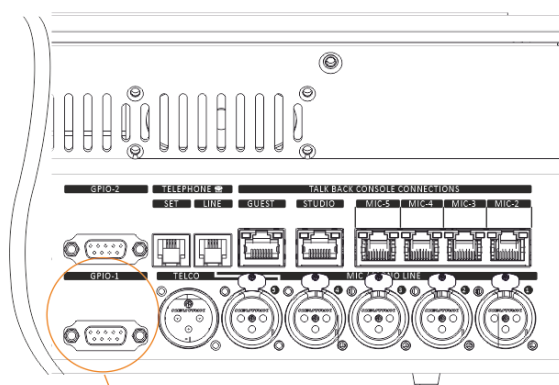
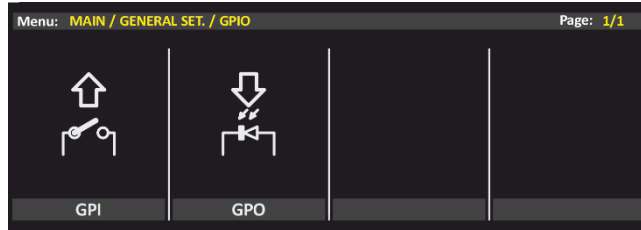

COMMUNICATIONS

From the GENERAL SET part of the menu, you can set the communication parameters like **IP, DNS, Date & Time, Time zone, NTP server**. The high flexibility in **Digital** console design gives you the full ability to set this terrific console as you like and as your audio projects are needed. For example, comes with two **TCP/IP** connections. One of them for monitoring, **WEB INTERFACE, REMOT CONTROL**, and data source (**NTP server**), and the second one we can use it to connect our console with other machine or software like **VJ PRO**.

TCP-IP

From the following pictures, you can see how to set the parameters for all the menus: **IP, MASK, and GATEWAY**. We will explain only one of these cases: the IP settings. The other cases work in the same way.

By rotating the 4 encoders you can set for a new IP Address.

Every encoder goes from **0** to **255**.

By pressing the encoder, you can confirm your choice.

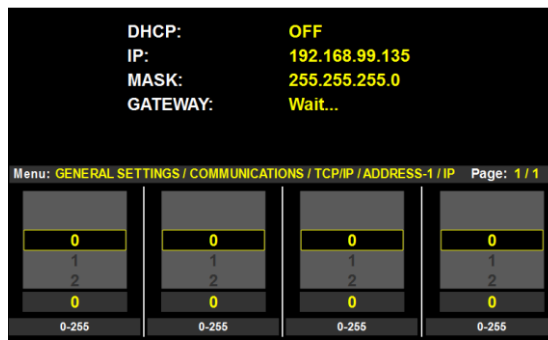

TIME&DATE

From the **General SET. / Communications / TIME&DATE** you can configure all parameters related to time and date.

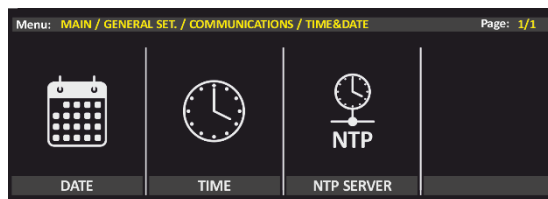

TIME

From the following section, you can set all the parameters related to the date settings. These data parameters are very important for device **LOGS**.

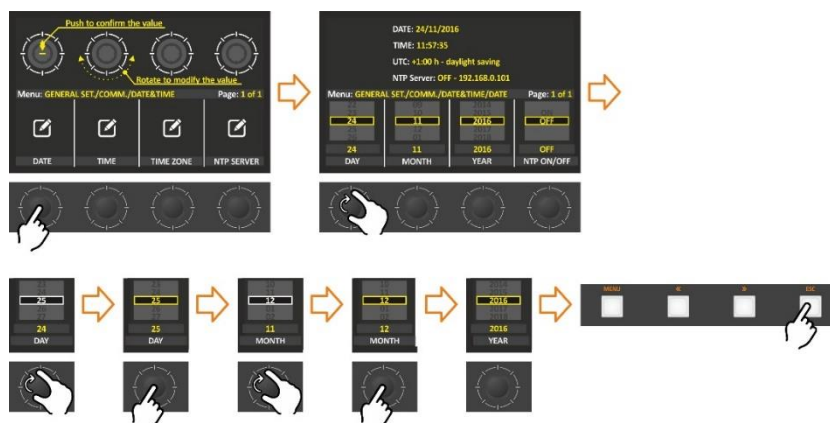

TIME ZONE

From this parameter, you can set for the **TIME ZONE**. You can set for the right Offset to the **UTC time**.



NTP

Network Time Protocol. This section contains all the settings related to **NTP** features. It is, in fact, possible to connect the device to an **NTP server**, and in this way, the device will synchronize its own date and time with the server.

NTP Server in the world:

- **europe.pool.ntp.org** (217.147.223.78)
- **asia.pool.ntp.org** (140.130.175.9)
- **oceania.pool.ntp.org** (203.23.237.200)
- **north-america.pool.ntp.org** (66.250.45.2)
- **south-america.pool.ntp.org** (146.164.53.65)
- **africa.pool.ntp.org** (196.25.1.9)

ACCESS CODE

The console gives the user the ability to lock the settings with a passcode to prevent any modifications by unauthorized persons. In fact, that is two different **Conditional Access** (4-digit PIN) to help if one of the two passcodes is forgotten.

- two different Passcode.
- The default passcode is **0000**.
- It can disable and enable both of them together by **ON/OFF** selection.
- Can set the passcode to lock the display after **10, 30, or 60 minutes**.

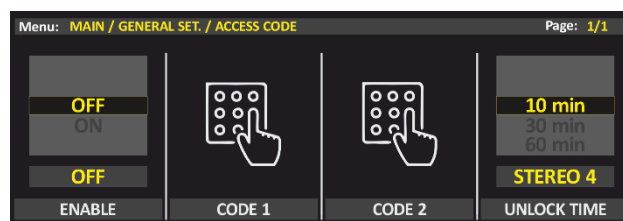

LIGHT & DISPLAY

From the following menu, you can set the display light and the led brightness.

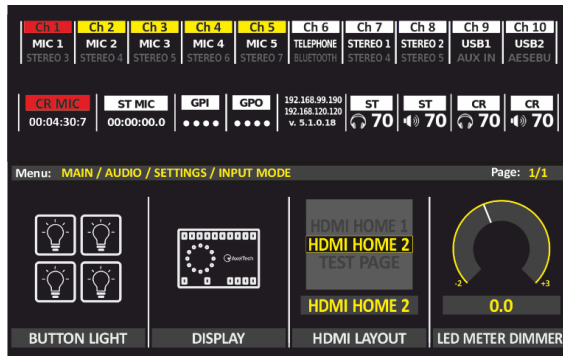

BUTTON LIGHT

in this section can set the light intensity of buttons. Also, it can set a different color for **MUTE**, **PFL**, and **MENU**.

That is also **4 editable colors** (color-1 to 4)

An RGB color value is specified with RGB (red, green, blue).

Each parameter (**red**, **green**, and **blue**) defines the intensity of the color as an integer between **0** and **255**.

For example, RGB (**0, 0, 255**) is rendered as **blue**, because the **blue** parameter is set to its highest value (**255**) and the others are set to **0**.

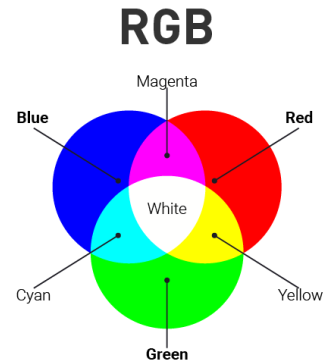

R	255	255	255	125	0	0	0	0	0	125	255	255
G	0	125	255	255	255	255	255	125	0	0	0	0
B	0	0	0	0	0	125	255	255	255	255	255	125

Just for example:

DISPLAY

From here, the display screen can be dimmed and change the HOME view style. also it possible to load the logo to be viewed on the main screen.

To have the logo of your own station on the Mixer display. The image must be **330x280px** in **PNG** format and named **logo.png** then but this logo on the USB memory stick and insert in the USB port at the rear of the mixer. click on **READ USB** to load it.

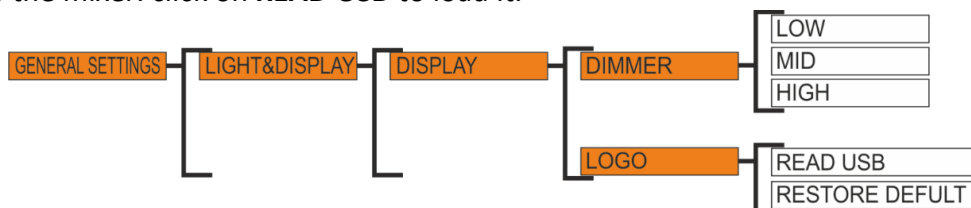

LED METER

Here you can set the LED METER Dimmer. Every LED METER will follow this set of light intensity. (From -2 to +3).

The console allows you to set and manage 2 different kinds of outgoing IP commands:

- The first **SMART KEY** kind could be managed by Smart Keys.
- the second **TRIGGER** kind could be managed by channel sliders and related ON/OFF buttons.



SMART KEYS

By clicking one of the Remoter - **Smart Key** (from **K1** to **K8**) buttons you can automatically send a **TCP** or a **UDP** or a **Rest API** Command to a remote application/device compatible with these 3 different communication protocols (For example, your Automation Software).

Each Smart Key could control the remote software by **IMPULSIVE** or **TOGGLE**.

IMPULSIVE: One Button Pressure (click).

TOGGLE: Two Button Pressure (first pressure for **ON** and second pressure for **OFF**). when clicked remains "down" (appearing to be pressed) until it is clicked again.

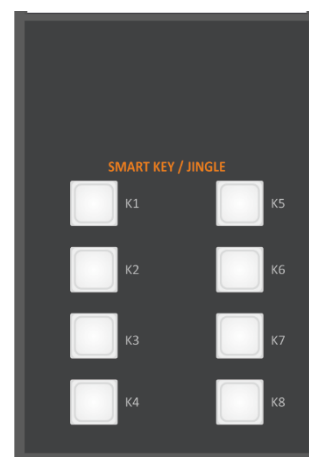

ONAIR TRIGGERS

TRIGGER commands associated with the channel slider (**fader**) and/or **ON/START** button press.

It can decide the command to be sent to the Remote **APP / Device** (for example, your Automation Software).

- at the slider **rise-up** or at the ON/START (**ON mode**) pressure (MACRO ON)
- at the slider **rise-down** or ON/START (**OFF mode**) pressure (MACRO OFF).

4. SERVICE



4.1 CONFIGURATION

One of the characteristics of the consol is that all settings can be saved on an external memory stick and can be called again when needed, and the settings can also be exported from one mixer to another.

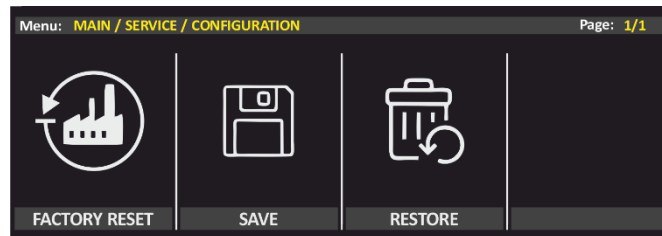

Factory reset

is a software restore of the mixer to its original system state by erasing all of the information stored on the mixer. The factory reset is used to restore the device to its original manufacturer settings. Doing so will effectively erase all of the data, and settings that were previously on the device. This is often done to fix an issue with a device, but it could also be done to restore the device to its original settings.

The mixer will ask the confirmation if you select the factory reset to be sure that you like to delete all settings to go back to the original manufacturer settings.

SAVE

To save the configurations, the mixer will ask if you like to save them in the internal memory **SD** or it can export them to the external memory stick.

RESTORE

Restore the previously saved system state. when you enter this section, you find all of the saved configurations divided according to the date and time.

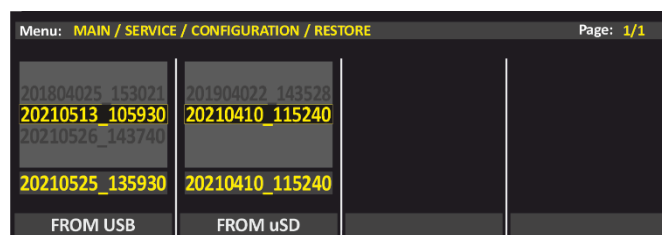

4.2 SOFTWARE



A. UPGRADE

MIXER FIRMWARE UPGRADE

must connect the **consol** to the internet. To do this using the **DHCP** or static **IP** address, go to:

MENU / SERVICE / COMMUNICATIONS / TCP-IP / ADDRESS-1 or 2 / DHCP

Active it by selecting **(ON)** or set the static IP that is given by your **IT-MAN**.

then go **MENU / SERVICE / SOFTWARE / UPGRADE**

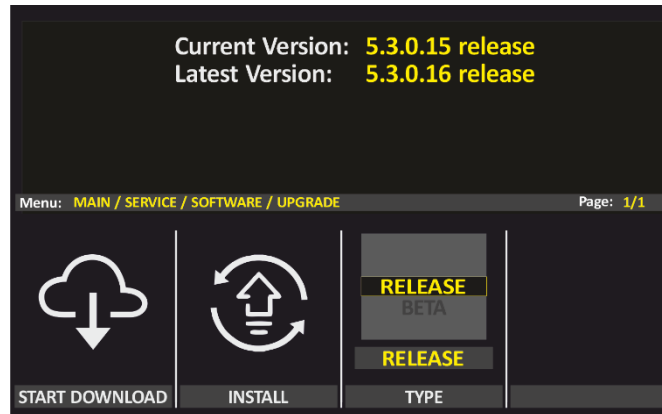

START DOWNLOAD: By pushing the knob of it, will start downloading the latest version available on the internet and it will show up the percentage of the processing.

INSTAL: When the download of the new version is done will see the message **“Upgrade is ready, install when ready”**. at this point, the icon of install will show in white color to indicate that is active, then you can push the knob to start installing the new version.

TYPE: By switching between **RELEASE** and **BETA** can know the **latest version** available and in the upper part of the display show up the number of the version.

UPGRADING PROCEDURE

1. Press the first knob (**start download**) to download the latest version.
2. When it is finished downloading, just click on the **INSTALL** knob to start the updating process.

ATTENTION:

- You have to wait until the system will finish the Upgrade. The system requires more or less 6 minutes. **DO NOT PROCEED WHEN THE MIXER IS ON-AIR.**
- At the end of the upgrade, the system will ask to REBOOT from the power switch. the firmware is upgraded.

B. VERSION



FIRMWARE

From the following section, you can read the parameters related to the firmware version.

Software and firmware version			
Environment	5.5.0.10 release	BRIDGE	1.1 OXY_USB
GUI	2.2.0.2	Master MCU	2.3
		DSP MCU	2.4
		CH1 MCU	2.2
		CH2 MCU	2.2
		CH3 MCU	2.2
		CH4 MCU	2.2
		CH5 MCU	2.2
MAC Address	02:22:07:82:03:C1		
Serial Number			
Uptime	10 days 02:55:31		

4.3 LOGS

the log file is a file that records either events that occur in an operating system or other software runs.

It possible to access the **LOG** file from here and save it to the **USB memory**. it is also accessible from the **REMOTER** software and the console **WEB interface**.

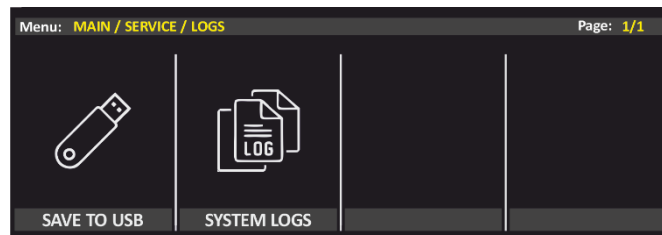

4.4 WEB LOGIN

the default WEB interface password is: **root**

By rotate and push you can select the password of the WEB login.

to cancel a character, scroll down and use <<.

TALKBOX CONNECTIONS AND FUNCTIONING

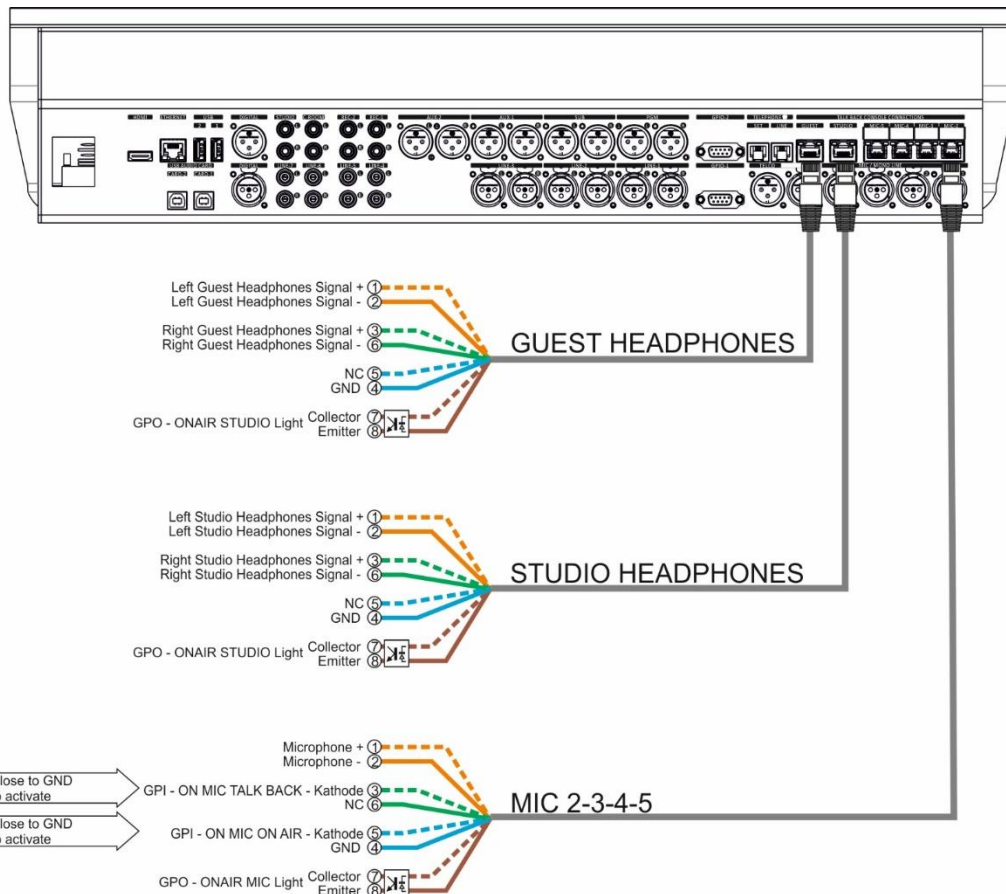
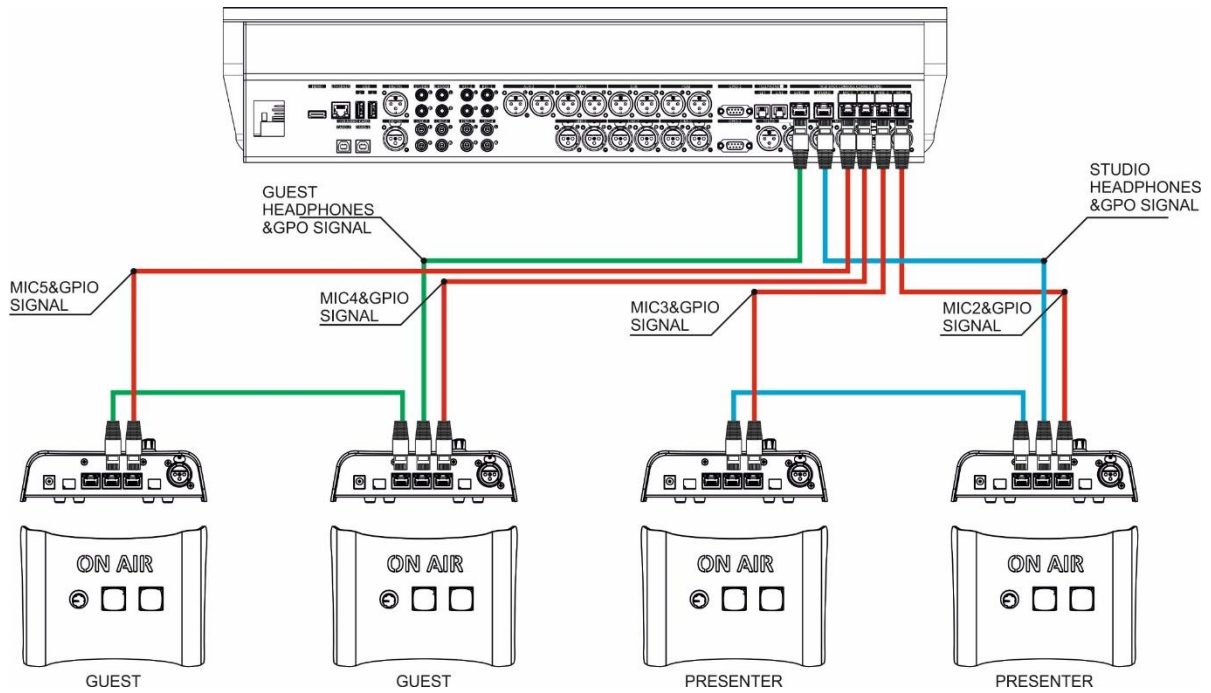

On the Console, it is possible to connect a maximum of 4 Talk boxes. Every Talk Box is physically connected with a Mixer MIC-source.

MIC2-> TB2

MIC3-> TB3

MIC4-> TB4

MIC5-> TB5*

- * MIC 5 works as a LINE input. It is designed to be a Telco input also.

Each TalkBox has two buttons corresponding to two **GPI** and lamps corresponding to two **GPO**. The two GPI correspond to the ON AIR button and Talkback:

ON-AIR Button

The ON-AIR button works parallelly with the **ON/START** mixer button.

If the MIC is in ON state on the MIXER, it is possible to disable the MIC from the Talkbox and vice versa. The GPI is in the RJ45 MIC connector.

ON-AIR LIGHT - MIC

The MIC ON-AIR light reflects the MIXER ON/START BUTTON. When the Channel is in ON state the MIC ON AIR light is on, when the Channel is in OFF state the MIC ON AIR light is off. This GPO is in the RJ45 MIC connector.

ON-AIR LIGHT -STUDIO

The STUDIO light reflects the logical operation (OR) between all Studio Microphones. If either or all the Studio Microphone/s is/were ON the light should be on, the light should be OFF only when all Microphones are OFF.

This GPO is in the RJ45 MIC connector.

TB Button

On each Talk Box, the TB button pressure sends the related mic signals to the Control Room SPEAKERS/HEADPHONES.

The TB button works impulsively. When the TB button pressure stops also the communication with the Control-Room will be stopped.

If you have a TalkBack signal, speakers or headphones will stay connected with the MIC source until you stop pressing the TB button.

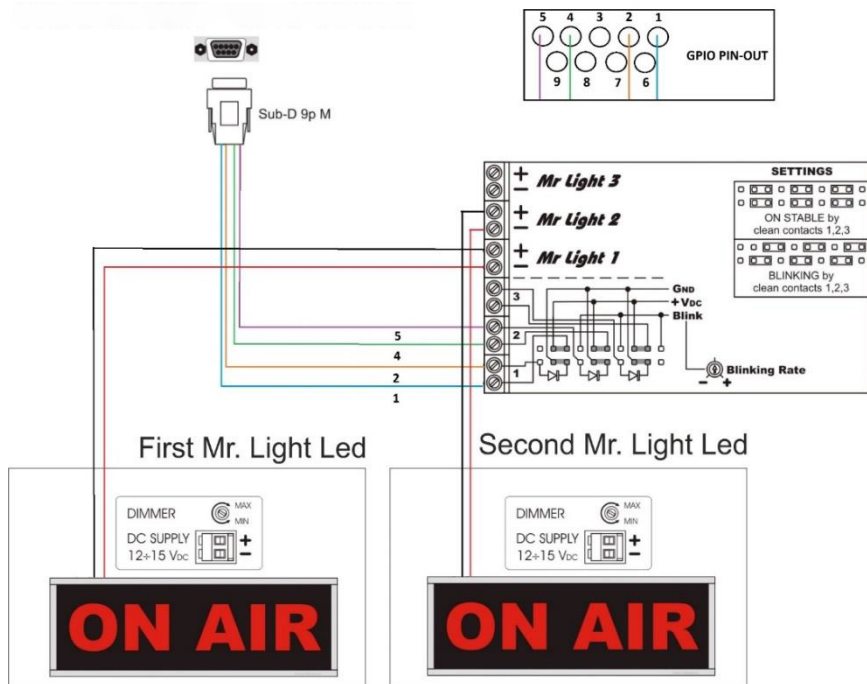
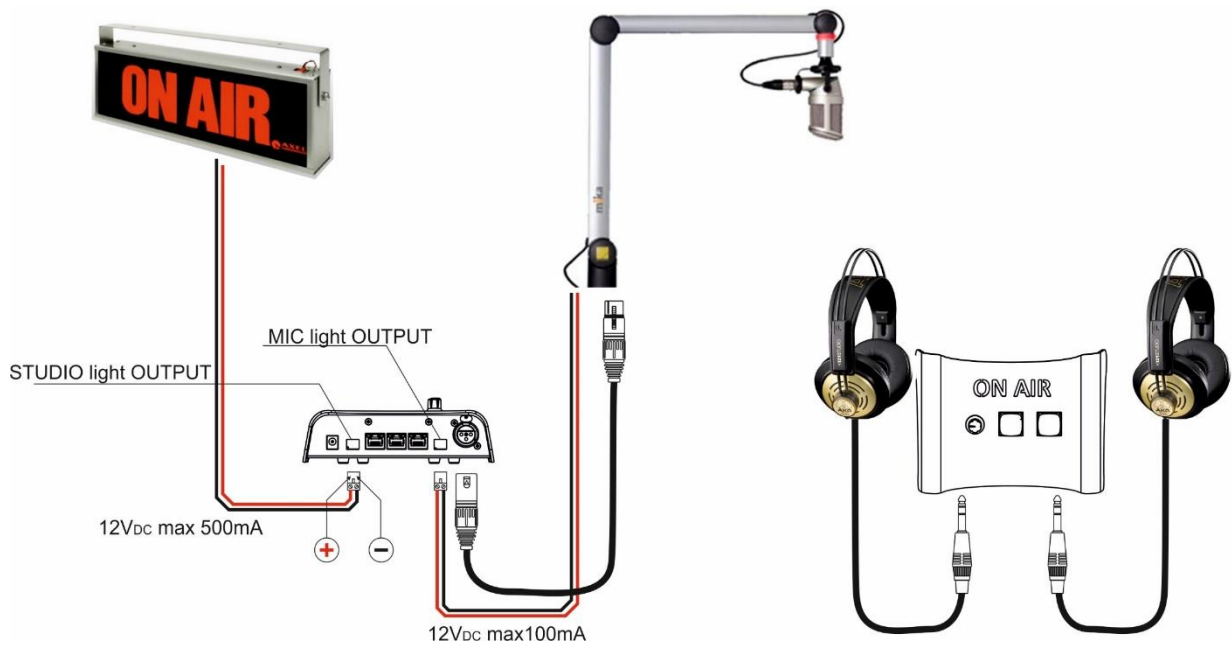

PINOUT OF CONNECTIONS

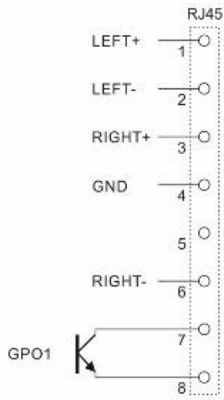

GUEST **STUDIO**

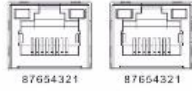

GUEST/STUDIO CONNECTION

- PIN 1 - LEFT SIGNAL +
- PIN 2 - LEFT SIGNAL -
- PIN 3 - RIGHT SIGNAL +
- PIN 4 - GND
- PIN 5 - N.C.
- PIN 6 - RIGHT SIGNAL -
- PIN 7 - GPO COLLECTOR
- PIN 8 - GPO EMITTER

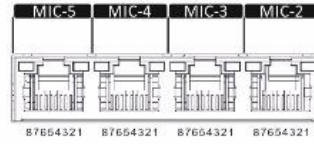

MIC CONNECTION

- PIN 1 - SIGNAL +
- PIN 2 - SIGNAL -
- PIN 3 - GPI1
- PIN 4 - GND
- PIN 5 - GPIO2
- PIN 6 - N.C.
- PIN 7 - GPO COLLECTOR
- PIN 8 - GPO EMITTER

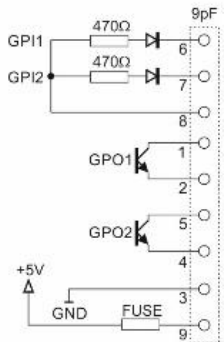
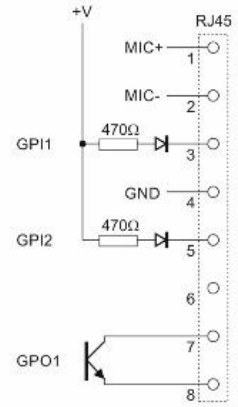

GPIO-1 **GPIO-2**

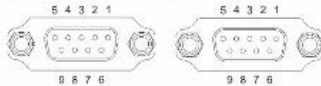

GPIO-1/GPIO-2 CONNECTION

- PIN 1 - GPO1 COLLECTOR
- PIN 2 - GPO1 EMITTER
- PIN 3 - GND
- PIN 4 - GPO2 EMITTER
- PIN 5 - GPO2 COLLECTOR
- PIN 6 - GPI1 CATHODE
- PIN 7 - GPI2 CATHODE
- PIN 8 - GPI COMMON
- PIN 9 - +5V

TELEPHONE

SET **LINE**

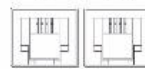

TELEPHONE CONNECTION

- PIN 1 - N.C.
- PIN 2 - TIP
- PIN 3 - RING
- PIN 4 - N.C.

PRODUCT	Oxygen 3000D	
CHECK	PART	Connectors
REV	000	TYPE LAYOUT
DATE	18-06-2018	COD. CS

Analog Balanced Stereo Inputs

Connector	XLR Balanced – EMI Suppressed
Input Impedance	10Kohm
Nominal Input Level (sensitivity)	0dBu
Max Input Level (clipping point)	+18,5dBu
A/D conversion	24 bit / 48 Khz
Frequency response	+/-0,5dB from 20Hz to 20kHz
Signal to Noise Ratio (referred to peak level)	>100dB
Stereo Separation (referred to peak level)	>90dB
THD+N	<0,002%

Analog Unbalanced Stereo Inputs

Connector	RCA unbalanced – EMI Suppressed
Input Impedance	10Kohm
Nominal Input Level (sensitivity)	0dBu
Max Input Level (clipping point)	+18,5dBu
A/D conversion	24 bit / 48 Khz
Signal to Noise Ratio (referred to peak level)	>90dB
Stereo Separation (referred to peak level)	>80dB
THD+N	<0,05%

Analog Balanced Microphone Inputs

Connector	XLR Balanced – EMI Suppressed
Input Impedance	2,4Kohm
Nominal Input Level (sensitivity)	-21dBu
Max Input Level (clipping point)	+7dBu

A/D conversion	24 bit / 48 Khz
Signal to Noise Ratio (referred to peak level)	>90dB
THD+N	<0,01%
Analog Gain	Adjustable +0 ÷ +60dB (3dB step)
Phantom Power	+48V

Analog Balanced Telco Input (shared with MIC5, mutually exclusive)

Connector	XLR Balanced – EMI Suppressed
Input Impedance	2,4Kohm
Nominal Input Level (sensitivity)	0dBu
Max Input Level (clipping point)	+18,5dBu
A/D conversion	24 bit / 48 Khz
Signal to Noise Ratio (referred to peak level)	>90dB
THD+N	<0,01%

Analog Balanced Stereo Outputs

Connector	XLR Balanced – EMI Suppressed
Output Impedance	23ohm, nominal 600ohm
Nominal Output Level	0dBu
Max Output Level (clipping point)	+18,5dBu
D/A conversion	24 bit / 48 Khz
Signal to Noise Ratio (referred to peak level)	>100dB
Stereo Separation (referred to peak level)	>90dB
THD+N	<0,002%

Analog Unbalanced Stereo Outputs

Connector	RCA Unbalanced – EMI Suppressed
Output Impedance	nominal 560ohm
Nominal Output Level	0dBu

Max Output Level (clipping point)	+19dBu
-----------------------------------	--------

D/A conversion	24 bit / 48 Khz
----------------	-----------------

Signal to Noise Ratio (referred to peak level)	>90dB
--	-------

Stereo Separation (referred to peak level)	>80dB
--	-------

THD+N	<0,05%
-------	--------

Analog Balanced Talkbox Outputs

Connector	RJ45 balanced – EMI Suppressed
-----------	--------------------------------

Output Impedance	100ohm, nominal 600ohm
------------------	------------------------

Nominal Output Level	0dBu
----------------------	------

Max Output Level (clipping point)	+14dBu
-----------------------------------	--------

D/A conversion	24 bit / 48 Khz
----------------	-----------------

Signal to Noise Ratio (referred to peak level)	>100dB
--	--------

Stereo Separation (referred to peak level)	>90dB
--	-------

THD+N	<0,05%
-------	--------

Analog Balanced Telco Output

Connector	XLR Balanced – EMI Suppressed
-----------	-------------------------------

Output Impedance	23ohm, nominal 600ohm
------------------	-----------------------

Nominal Output Level	0dBu
----------------------	------

Max Output Level (clipping point)	+18,5dBu
-----------------------------------	----------

D/A conversion	24 bit / 48 Khz
----------------	-----------------

Signal to Noise Ratio (referred to peak level)	>100dB
--	--------

THD+N	<0,002%
-------	---------

Digital Input

Connector	Balanced on 1 XLR – EMI Suppressed
-----------	------------------------------------

Input Impedance	110Ω
-----------------	------

Standard	AES3
----------	------

Audio Sample Rate	32/44.1/48KHz with aSRC
-------------------	-------------------------

Resolution	24 bit
------------	--------

Dynamic Range (Converter Values)	124dB
----------------------------------	-------

Digital Output

Connector	Balanced on 1 XLR – EMI Suppressed
-----------	------------------------------------

Input Impedance	110Ω
-----------------	------

Standard	AES3
----------	------

Audio Sample Rate	48KHz
-------------------	-------

Resolution	24 bit
------------	--------

Dynamic Range (Converter Values)	124dB
----------------------------------	-------

USB Audio Digital I/O

Connector	USB Type B – EMI Suppressed
-----------	-----------------------------

Playback and Recording Sample Rate	48KHz fixed
------------------------------------	-------------

Resolution	16 bit
------------	--------

Channel count	1 Stereo play, 1 stereo rec for each USB interface
---------------	--

PSTN Interface

Connector	RJ11
-----------	------

Trans hybrid loss	>36dB
-------------------	-------

System

Audio Core	Analog Devices ADAU1452 32bit 294MHz fixed point DSP
------------	--

Audio CODECs	Cirrus CS42448 24bit/192kHz
--------------	-----------------------------

System Core	Allwinner A20 dual-core cortex-A7 at 800MHz, 1GB RAM
-------------	--

System display	7" TFT 800x480 LCD
----------------	--------------------

LAN Connection	RJ45 - 100Mbit
----------------	----------------

Nominal Delay (analog input to analog output)	0,7ms
---	-------

GPIO Inputs/Outputs	12 GPI / 10 GPO
---------------------	-----------------

Communication Port	2xUSB type-A, 2xUSB type-B , 1xLAN, 1xHDMI
--------------------	--

Operating Temperature	0°C ÷ 40°C
-----------------------	------------

PSU (optionally redundant)

Power Supply	90-260 Vac / 47-63 Hz 45W
--------------	---------------------------

Dimensions

Dimensions (W; H; D)	660mm; 142mm; 540mm
----------------------	---------------------

Weight	< 20Kg
--------	--------